



United States  
Department of  
Agriculture

National  
Agricultural  
Statistics  
Service

Agricultural  
Statistics  
Board

Washington  
D.C. 20250

**June 2024**



# 2024 Corn Objective Yield Survey

## Interviewer's Manual



---

<b>Chapter 1 – Corn Objective Yield Survey .....</b>	<b>101</b>
General .....	101
Purpose .....	101
Farmer Benefit .....	102
Development of Objective Yield Surveys.....	103
Use of Reports Issued by USDA .....	103
Reports from Corn Objective Yield Surveys.....	104
The Sample .....	104
How Rows and Paces are Determined for Objective Yield .....	104
Equipment.....	105
List of Equipment and Supplies.....	105
Quality Control and Supervision .....	106
Pesticide Safety.....	107
Determining Use of Organophosphorus Pesticides .....	107
Common Symptoms of Pesticide Poisoning .....	107
Medical Attention .....	108
Field Re-Entry Intervals.....	108
Field Re-Entry Intervals Following Chemical Applications .....	108
Protection Against Pesticide Exposure .....	109
Protective Clothing .....	109
Soap and Water for Decontamination.....	109
Organophosphorus Chemicals Commonly Used in Corn Production .....	109
Sample Field Kits .....	110
Sample Field Kit Envelope .....	111
Guidelines for Completing the Questionnaire.....	112
Operations with Multiple Samples .....	112
Locating the Sample Operators .....	112
Producer Letter Example .....	113
Turning in Completed Corn Samples .....	114
Monthly Program.....	114
September 1 Survey.....	115
October 1 Survey .....	115
November 1 Survey.....	115
Final Pre-harvest .....	115
Post-harvest Gleanings Survey .....	115

---

<b>Chapter 2 – Terms &amp; Definitions</b> .....	<b>201</b>
General .....	201
Common Objective Yield Survey Terms.....	201
<b>Chapter 3 – Form A Interview</b> .....	<b>301</b>
<b>General</b> .....	301
<b>Multiple Samples in Same Tract</b> .....	301
FORM A-1 .....	303
<b>Chapter 4 – Unit Location</b> .....	<b>401</b>
General .....	401
Unit Location and Layout.....	401
Locating Unit 2.....	406
Preparing Sketch of Sample Units.....	406
Twin Row Procedures .....	406
Twin Rows Sample Unit Location.....	406
Twin Row Space Measurements.....	407
Laying Out Twin Row Units .....	407
Special Problems in Laying Out Units .....	408
Seed Corn Fields.....	408
Locating a Unit in Fields with End Rows .....	408
Blank Area that was Deducted.....	409
Blank Area or Other Crop Not Deducted .....	409
Bounce Back Techniques .....	410
Rows Change Directions .....	411
Locating Units in Odd Shaped Fields.....	412
Fields with Blocking and Blank Area Not Deducted.....	413
Fields with Blocking and Blank Area Deducted.....	414
Units Fall beyond End of Field.....	415
Center Pivot Fields - Starting Corners.....	416
Center Pivot Fields .....	417
Spiral or Circular Fields .....	418
<b>Chapter 5 – Form B</b> .....	<b>501</b>
General .....	501
Data Quality .....	501
Sample Identification.....	504
Pesticide Safety.....	504
Unit Location.....	505

Row Space Measurement .....	Table of Contents	505
Single Row Planted Row Space Measurements.....		506
Twin Row Planted Row Space Measurement .....		507
Maturity .....		508
Corn Maturity Codes.....		508
Maturity Code 2 - Pre-blister .....		508
Maturity Code 3 – Blister .....		508
Maturity Code 4 – Milk .....		508
Maturity Code 5 – Dough.....		508
Maturity Code 6 – Dent .....		508
Maturity Code 7 – Mature .....		509
Kernel Row and Diameter Measurements .....		511
Maturity Stage 6 Ear Weights .....		514
Counts Within 15-Foot Units .....		514
Harvesting Sample Units.....		516
Special Problems.....		518
Completing Corn Sample ID Tag .....		520
Identification.....		520
Twin Row Sample Harvest .....		521
Preharvest.....		521
At Harvest .....		521
Post-harvest.....		521
Shipping Samples to the Objective Yield National Lab .....		524
UPS 2 <sup>nd</sup> Day Air or UPS Next Day Air Option .....		525
USPS Option .....		525
The Dos & Don'ts of Packaging and Shipping Corn Samples .....		526
<b>Chapter 6 – Form E .....</b>		<b>601</b>
General .....		601
Form E.....		601
<b>Chapter 7 – CAPI Data Entry .....</b>		<b>701</b>
General .....		701
Survey Designer and Edit System.....		701
CAPI Form B Status Codes.....		702
Corn Form B Status Code Definitions.....		703
1- Complete (Form B expected Next Visit) .....		703
2- Farmer Harvested for Grain Before Units Were Laid Out .....		703

Table of Contents

---

3- Farmer Harvested for Grain after Units were Laid Out .....	704
4- Enumerator Harvested Sample Units .....	704
5- Field Partially Destroyed – Both Units Destroyed .....	705
6- Lost Sample – Field NOT Harvested for Grain .....	705
7- Refusal .....	706
8- Inaccessible (Form B expected Next Visit).....	706
11- Sample Field Planted to Corn but Not For Harvest as Grain .....	707
12- Corn for Grain in Tract but Not Planted for ANY Purpose in the Sample Field.....	707
13- No Corn Planted For ANY Purpose in Tract .....	708
CAPI Response Coding .....	709

## Chapter 1 – Corn Objective Yield Survey

### General

You are one of about 300 enumerators in 10 States employed to obtain information from farmers about their corn fields and to make a series of observations on these fields. This Objective Yield Survey is a part of an overall program to provide estimates of crop yields and acreages. Objective Yield Surveys have been conducted for many years and have provided reliable indications of yield.

States participating in the Corn Objective Yield program include IA, IL, IN, KS, MN, MO, NE, OH, SD, and WI. In these States, interview and field work will be completed for all samples.

The importance of your work will become apparent as you read how these surveys operate. Briefly, your job consists of interviewing designated farm operators and making some monthly observations in one or more of their corn fields. The operators were selected from the June Area Survey conducted in early June. Monthly visits to the fields start in late August and continue until each field reaches maturity. On the first contact, you will talk to the operator, identify the sample field(s), and complete an interview for each sample field. These observations are recorded on a Form A.

In the sample field, you will mark off two small plots called "units" in which you will make plant and fruit counts each month during the growing season. These field observations are recorded on a Form B.

When the crop is mature, you will harvest part of the sample units and ship a small sample of the crop to a lab where it will be weighed and tested for moisture content. Soon after the crop is harvested, you will glean some of the fields. Form E is used for gleaning observations and is completed for one-fourth of the samples.

The terms "Objective Yield Survey" and "Objective Yield Forecasts" are used frequently in this work. The term "objective" means that the basic information is based upon actual counts and measurements. Objective Yield Surveys are scientifically designed; and field observations and measurements must be made precisely according to prescribed procedures given in this manual. Objective yield forecasts are based on counts and measurements of a crop after it has emerged and before it is mature. The accuracy of each crop production forecast depends directly upon your performance and the performance of all other enumerators working on this survey.

### Purpose

The Corn Objective Yield Survey is to provide:

1. Counts and measurements on this crop which can be used to forecast or estimate crop yields per acre on September 1, October 1, November 1, and at the end of the season.
2. Counts and weight of corn left in the field after harvest to estimate harvesting loss per acre.
3. Changes in acreage intended for harvest that result from fields being plowed up or destroyed after the June Area Survey, but before harvest.

Following procedures for this survey, you and other enumerators will obtain counts of plants growing in specified areas of sample fields throughout your State. Mature corn growing within the sample units will be harvested according to prescribed procedures. The various counts and measurements you obtain on the monthly surveys are combined and used with forecasting formulas to predict yields per acre. Estimates of yield are obtained at harvest time when you harvest the sample units. Objective Yield Survey results have shown that these various field counts and measurements provide reliable forecasts and estimates of yield for individual States and for the Nation. The sample units are too small, however, to provide reliable yield estimates for an individual field.

In late August, you and the other enumerators in the 10 States will enter corn fields to mark off objective yield units. It is most important to locate these units properly and make all counts and measurements accurately.

2022 Corn Objective Yield Survey Statistics	
Number of States in Program .....	10
Estimate Samples Laid Out .....	1,015
Total Acreage in Sample Units .....	3.50
Harvested Acres in OY States .....	66,420,000
Percent of U.S. Acres Harvested .....	80.5%
Percent of U.S. Crop Production .....	83.1%

From the table above you can understand why careful, accurate field work is so vital to this survey.

### Farmer Benefit

The purpose of the objective yield survey is to accurately predict the production of corn crops at the State, Regional and National levels beginning with the September 1 forecast in the September Crop Production report.

As you know, the size of these crops and any change in the size are crucial information needed by many people involved in agriculture. Therefore, our reports make national news as these crops near harvest time.

The individual most needing this information is the farmer, for only with accurate statistical information about the size of these crops can the farmer make knowledgeable decisions about:

1. Marketing Strategies – Information used to sell early using forward contracts, to hedge on the futures markets, to sell on the cash market, or to use any of these in combination.
2. Farm Business Practices – Information used to make decisions on various aspects of farm business operations, such as: Using On-Farm storage in place of selling and/or storing at the local elevator, or changing intended usage of a planted crop.

The objective yield survey provides factual information which is a tool farmers can use to make knowledgeable business decisions. This tool is needed by any farmer who sells corn.



## **Development of Objective Yield Surveys**

The National Agriculture Statistics Service (NASS) has forecasted and estimated the yield of major crops for many years. Although crop acreage changes from year to year, some of the largest variations in crop production are caused by fluctuations in yield. For nearly a century NASS based its yield forecasts on voluntary producer appraisals of expected yield. Objective field measurement surveys were developed to compliment grower surveys and allow statisticians to fine-tune crop forecasts.

Work using objective yield measurements on wheat, corn and cotton began in the late 50s. The increasingly important soybean crop was added in the early 60s.

Forecasts and estimates using objective yield procedures are based on:

1. Actual counts and measurements made in sample fields by trained enumerators.
2. Data obtained by technicians making laboratory analyses of fruit from the crops.

Two components of objective yield data:

1. Weight of the fruit and number of fruit (pods, bolls, ears, etc.) are used to calculate a biologically based yield.
2. Post-harvest gleanings data is used to estimate harvest losses. The gleanings estimate is subtracted from the gross yield estimate derived from pre-harvest sample data to obtain a net yield estimate for each state.

## **Use of Reports Issued by USDA**

Reports issued by the Department of Agriculture provide reliable and timely information for use by farmers, bankers, credit associations, buyers, agricultural economists, policy makers, etc. When all participants in the industry are accurately and equally informed by an unbiased source, no one has the advantage of rumors or other special information that could unfairly influence prices.

These reports may reach the farmer through farm magazines, commodity news service reports, Internet, television, radio, newspapers, etc. Virtually all of these reports are based on NASS crop reports. In addition, farmers and other data users can request reports through their State Field Office.

Sometimes farmers feel that USDA reports only drive prices down. It is true that prices may change based on crop reports. In the long run, however, it's the actual supply entering the market along with demand that determines prices received by farmers. Reports have had a positive effect on prices as often as a negative effect over the years.

Remember, if unbiased crop reports were not available to all parties, industry reports would be the only data available for farmers to use.

### Reports from Corn Objective Yield Surveys

<b>September Crop Production</b> <ul style="list-style-type: none"><li>• Acreage, Yield and Production (<i>forecast</i>)</li></ul>	September 12, 2022
<b>October Crop Production</b> <ul style="list-style-type: none"><li>• Acreage, Yield and Production (<i>forecast</i>)</li></ul>	October 12, 2022
<b>November Crop Production</b> <ul style="list-style-type: none"><li>• Acreage, Yield and Production (<i>forecast</i>)</li></ul>	November 9, 2022
<b>Annual Summary</b> <ul style="list-style-type: none"><li>• Acreage, Yield and Production (<i>final, all crops</i>)</li></ul>	January 10, 2023 ( <i>Tentative Date</i> )

### The Sample

The corn fields included in the Objective Yield Surveys are selected from corn reported in the tracts enumerated during the June Area Survey. The sample is drawn so that the probability of any field being chosen is proportional to the size of that field. A 40-acre field is twice as likely to be selected as a 20-acre field. The sample includes small fields as well as large ones. In some cases, a large field is chosen two or more times. This field will have two or more objective yield samples assigned to it.

### How Rows and Paces are Determined for Objective Yield

There is an upper limit on the field acres which are used to determine rows and paces. For corn, cotton, , and soybean surveys, the acres are set to 80 if there are more than 80 acres in the field. For all the wheat OY crops, the maximum field acres used are 128 acres. The field is assumed to be rectangular and the width is calculated as 5/8 of the length. These numbers are converted to paces and random numbers used to generate row and pace counts.

When corn, cotton, and soybean, row and pace counts are generated, an adjustment is made so that the sample falls within 1/4 of the field (using the maximum field size described above). For wheat, when the number of rows and paces are generated, an adjustment is made so that the unit 1 sample falls within 1/4 of the field if field acres are  $\leq 60$  acres, and within 1/9 of the field if field acres are  $> 60$ .

These adjustments limit how many rows and paces the enumerators need to walk into the fields. For corn, cotton, and soybean surveys, the maximum number of rows possible is 296 and the maximum number of paces is 473. (Unit 2 is then calculated as Unit 1 + 30 more paces).

For wheat, the maximum number of rows for unit 1 is 409 and the maximum number of paces for unit 1 is 256. (Unit 2 is then calculated as Unit 1 + 30 more paces).

## Equipment

The items of equipment and supplies which will be used on the Corn Objective Yield Survey are listed below. Your supervisor is responsible for furnishing all your necessary supplies and equipment; you are responsible for the proper use and care of all items provided. If your supplies run low or equipment becomes unusable, notify your supervisor immediately.

### List of Equipment and Supplies

<input checked="" type="checkbox"/>	ITEM	<input checked="" type="checkbox"/>	ITEM
<input type="checkbox"/>	Interviewer's Manual	<input type="checkbox"/>	Anchor Pin
<input type="checkbox"/>	Identification Card	<input type="checkbox"/>	Hatchet (optional)
<input type="checkbox"/>	Form NAS-011 (Time and Mileage)	<input type="checkbox"/>	Red Florist Stakes
<input type="checkbox"/>	Motor Vehicle Accident Report Kit	<input type="checkbox"/>	Blue Florist Stakes
<input type="checkbox"/>	EPA booklet "Protect Yourself from Pesticides"	<input type="checkbox"/>	Unit Location Stakes
<input type="checkbox"/>	First Aid Kit	<input type="checkbox"/>	Corner Stakes (optional)
<input type="checkbox"/>	County Maps	<input type="checkbox"/>	Flagging Ribbon
<input type="checkbox"/>	State Highway Map	<input type="checkbox"/>	Red Plastic Tags
<input type="checkbox"/>	Canvas Satchel	<input type="checkbox"/>	Caliper
<input type="checkbox"/>	Canvas Bag or Carpenter's Apron	<input type="checkbox"/>	Cloth Bags for Code 6 Ears
<input type="checkbox"/>	Clipboard	<input type="checkbox"/>	Paper Bags
<input type="checkbox"/>	3-Ring Notebook	<input type="checkbox"/>	Poly Bags
<input type="checkbox"/>	Sample Field Kit Envelopes	<input type="checkbox"/>	Rubber Bands
<input type="checkbox"/>	Extra copies of Forms	<input type="checkbox"/>	Corn Scales
<input type="checkbox"/>	Aerial Photos	<input type="checkbox"/>	Tripod (optional)
<input type="checkbox"/>	Photo Mailing Boxes	<input type="checkbox"/>	Sample ID Tags
<input type="checkbox"/>	Ball Point Pen	<input type="checkbox"/>	Shipping Labels or Address Tags
<input type="checkbox"/>	Black Marker	<input type="checkbox"/>	Tyvek Envelope
<input type="checkbox"/>	Pencils-Red & Blue Lead	<input type="checkbox"/>	Kraft Envelope-9-1/2" x 12"
<input type="checkbox"/>	Tape, 12 foot in tenths of inches	<input type="checkbox"/>	White Envelopes letter size
<input type="checkbox"/>	Tape-50 foot in tenths of feet	<input type="checkbox"/>	Masking Tape
<input type="checkbox"/>	Four-foot Wooden Dowel Stick		

Unused supplies are to be returned to the State Field Office at the end of the season when instructed by your Survey Statistician.

### **Quality Control and Supervision**

The Objective Yield Quality Control program is designed to aid in the supervision of enumerators, detect faulty equipment, and to assure that proper survey procedures are followed. A good quality control program will improve the results of the Objective Yield Survey.

The Survey Statistician is responsible for the overall objective yield program. The Survey Statistician provides most of the training at your State Workshop and the necessary equipment and supplies needed for you to complete your assignments.

The Supervisory Enumerator is your immediate supervisor. Your supervisor will provide much of the "on site" field training you will need to complete your assignments. Your supervisor will also spend several hours with each enumerator during the first few days of each survey period. New enumerators will be visited first and if necessary, revisited after they have completed samples on their own.

Each Supervisory Enumerator will complete at least one quality control form (Q-1) for each enumerator under his or her supervision for each crop assigned. Upon receipt of completed Form B records, the Survey Statistician will inform the supervisory enumerator of the samples selected for quality control. Samples previously worked with the supervisor will be excluded. Whenever possible, the supervisor and the enumerator should return to the sample field together while the supervisor completes the Q-1 check of the enumerator's counts. The supervisor and enumerator must discuss any differences in counts and the reason for these differences. These differences will be resolved with the enumerator and documented on the Form Q-1.

## **Pesticide Safety**

Organophosphorus insecticides have been in common use for several years. Organophosphorus insecticides are used on most crops. Extreme caution must be taken to avoid overexposure to these insecticides.

A comprehensive pesticide safety program has been developed for all employees who may be exposed to pesticides while working on the Corn Objective Yield Survey. The program is designed to protect you from the possibility of overexposure to harmful pesticides.

Overexposure to pesticides, particularly insecticides, could result from home, garden and farm use, as well as unrestricted work in objective yield fields. Objective yield survey work, however, will pose little or no danger to your health when the safety precautions listed in these instructions are followed. Consult your copy of the EPA booklet, "Protect Yourself from Pesticides - Guide for Agricultural Workers", for additional information.

The safety program provides for monitoring and restricting exposure to organophosphorus insecticides. These insecticides are highly toxic to humans within several hours after application. The toxicity drops over time, but the rate of decline depends on the product used, application rate, weather factors and other variables.

## **Determining Use of Organophosphorus Pesticides**

You will ask if any pesticide with organophosphorus content has been applied in the past month. If yes, you will obtain the name of the pesticide and the latest application date. You should explain to the operator that you work in many fields on many different farms during a short period of time and that the sole purpose of the question is to ensure that you will not be unnecessarily exposed to harmful insecticides. Informative notes, such as: "The operator will not apply a pesticide;" "He will apply some later;" The name of the pesticide applied and the last application date; should be entered on the kit envelope for future reference.

Be sure and ask the operator where the information on pesticide spraying will be posted, so you can check it every month before you enter the sample field. Enter the location on the kit envelope.

The symptoms of pesticide poisoning may resemble fatigue or other common symptoms of illness. However, you can protect yourself by knowing and being alert to the early warning signs of poisoning.

## **Common Symptoms of Pesticide Poisoning**

- Headaches
- Dizzy spells
- Nervousness
- Sudden weakness
- Sick stomach
- Cramps
- Vomiting
- Diarrhea
- Heavy sweating
- Breathing difficulty
- Seizures
- Coma
- Pupils of the eye reduced in size

### Medical Attention

Go to the nearest qualified physician if poisoning symptoms appear. Explain your symptoms to the doctor and tell him you have been working in the fields where insecticides may have been applied. Use Form A, Form B or kit envelopes to determine the names of insecticides applied to fields where you have recently worked. Give this information to the doctor. Do not return to work on Objective Yield Surveys without the doctor's permission and the Survey Statistician is notified.

**IMPORTANT:** Notify your survey statistician immediately any time medical attention is required.

A list of organophosphorus insecticides that are commonly used in corn production is provided on the next page. The list includes the common names of recommended insecticides along with many trade names. If a trade name is not listed, you should determine the common name of the insecticide from the farm operator, insecticide dealer or County Extension Service. If an insecticide does not appear on the lists, the insecticide dealer or your County Extension Service should be able to tell you if it is an organophosphorus insecticide.

If on the initial Form A or Form B the operator informs you they will not apply any pesticide with organophosphorus content, you should put a note to that effect on the kit envelope. But, if you arrive at the sample field and it appears the operator has applied a pesticide (due to odor in the air, residue on leaves, spraying or dusting machinery or other evidence), contact the operator before continuing your observations.

If the operator applied a pesticide or is undecided, you should contact him each month to check on the application date and follow the field re-entry intervals specified below.

### Field Re-Entry Intervals

The **field re-entry interval** is the amount of time that **MUST** pass after pesticides are applied before entering the field. The intervals must be observed without exception to safeguard your health. The intervals provided are not expected to interfere with completion of your assignment unless some extremely unusual pest management practices are followed.

#### Field Re-Entry Intervals Following Chemical Applications

Chemical Type:	Any Chemical	Organophosphorus Chemical	
		Timing of Application:	Entry Restrictions:
Timing of Application:	Previous 24 hours	Previous 72 hours	Previous 30 days
Entry Restrictions:	Do Not Enter Field	Do Not Enter Field <sup>1</sup>	Follow Safety Requirements <sup>2</sup>

<sup>1</sup> Field re-entry is permitted 72 hours after application was made.

<sup>2</sup> Prior to entering fields treated with an organophosphorus chemical application within the last 30 days, you must:

- Wear a long sleeve shirt, long trousers and head covering.
- Not wear any clothing more than one day without laundering.
- Limit work time to a maximum of 6 hours per day in these fields.
- Thoroughly wash all exposed skin (hands, face, etc.) that may have come into contact with plant foliage during the field visit.

## Protection Against Pesticide Exposure

### Protective Clothing

Wear a long sleeve shirt, long trousers and head covering when working in fields that have had organophosphorus pesticides applied within the past 30 days. Do not wear clothing exposed to organophosphorus residues for more than one day. Take care in storing and laundering clothing to avoid possible cross-contamination of other clothing. When plant foliage is wet, wear water resistant or waterproof protective gear to prevent absorption of insecticides.

### Soap and Water for Decontamination

Each enumerator must carry water and bath soap when they work in fields that have had applications of organophosphorus insecticides. Upon completing work in such a field, thoroughly wash all exposed skin areas (hands, face) that may have contacted plant foliage.

### Organophosphorus Chemicals Commonly Used in Corn Production

<u>Trade Name</u>	<u>Common Name</u>
Fortress .....	Chlorethoxyphos
Lorsban .....	Chlorpyrifos
Cygon, Dimethoate .....	Dimethoate
Di-Syston .....	Disulfoton
Orthophos, Phoskil.....	Ethyl Parathion
Cythion, Malathion .....	Malathion
Pennacp-M, Methyl Parathion.....	Methyl Parathion
Thimet.....	Phorate
Aztec .....	Tebupirimiphos
Counter .....	Terbufos
<b>Pyrethroids</b>	
Capture .....	Bifenthrin
Baythroid .....	Cyfluthrin
Asana .....	Esfenvalerate
Warrior.....	Lambda-cyhalothrin
Ambush, Pounce .....	Permethrin
Force .....	Tefluthrin
<b>Carbamates</b>	
Temik .....	Aldicarb
Sevin.....	Carbaryl
Furadan.....	Carbofuran

### **Sample Field Kits**

For each sample field you will be given a large envelope containing the necessary forms for completing the work in that field. On the face of the envelope is listed the crop, sample number(s), county, segment number, tract, operator's name, address and phone number if available, "YES" or "NO" to "Lives in Segment", sample unit location information and the survey date each sample is to be laid out.

The number and kind of forms in the sample field kit envelope will vary according to the month each sample is laid out. The necessary identification has been printed on these forms by the State office. If there is more than one sample in a field, this information will be shown on the face of the kit envelope and there will be additional sets of forms as needed for each sample. A set of forms for each sample is included in the kit envelope.

When you make your first visit to each field, sketch a map on the face of the kit envelope showing the sample field, starting corner and unit locations. Make the map as large and clear as possible. If for any reason you are unable to complete your work, your supervisor or another enumerator should be able to return to the sample field and locate the units without difficulty by using your map. Indicate highway or farm road numbers and approximate mileage to the sample field.



Sample Field Kit Envelope

UNITED STATES DEPARTMENT OF AGRICULTURE  
NATIONAL AGRICULTURAL STATISTICS SERVICE  
Washington, D. C. 20250

Official Business

STATE \_\_\_\_\_ Crop \_\_\_\_\_

Variety \_\_\_\_\_  
\*\*Sample Field\*\*

County \_\_\_\_\_

Segment No. \_\_\_\_\_ Tract and Field Code \_\_\_\_\_

Lives in Segment? ( ) YES ( ) NO

LSF POID \_\_\_\_\_

Operator's Name \_\_\_\_\_

Address \_\_\_\_\_

Phone ( ) \_\_\_\_\_

Expected Harvest Date \_\_\_\_\_

Sample Field Pesticide Use Name \_\_\_\_\_

Schedule \_\_\_\_\_

NOTES: \_\_\_\_\_  
\_\_\_\_\_  
\_\_\_\_\_

FIELD SKETCH

North  
↑

**\*\*SAMPLE UNIT LOCATION\*\***

Sample No. _____ To be laid out _____	(Month)	
	Unit 1	Unit 2
Rows/Paces along edge		
Paces into field		
Sample No. 1/ _____ To be laid out _____	(Month)	
	Unit 1	Unit 2
Rows/Paces along edge		
Paces into field		
Sample No. 1/ _____ To be laid out _____	(Month)	
	Unit 1	Unit 2
Rows/Paces along edge		
Paces into field		
Sample No. 1/ _____ To be laid out _____	(Month)	
	Unit 1	Unit 2
Rows/Paces along edge		
Paces into field		

1/ Additional sample in this sample field

### **Guidelines for Completing the Questionnaire**

1. Entries must be legible and made in black lead pencil.
2. Put all entries in the boxes provided. Note the preprinted decimal. Do not write in any bold outlined office use box unless instructed to do so.
3. Write notes in the margins or blank spaces to clarify or explain entries.
4. Record all acreage entries to the nearest tenth acre. If whole acres are reported, enter a zero to the right of the decimal point.

### **Locating the Sample Operators**

First, study your county highway map and locate the segments which have sample tracts. The field kit envelopes indicate the segment numbers. Make sure you can find each segment on the county map for which you have a sample field kit envelope.

Your first contact attempt should be by phone. Try to complete for A during this contact. If that is not possible, try to set up an appointment to meet with the operator. If no contact by phone is possible, then there is a need to locate the farm operator.

Look over each aerial photo and make sure you locate the designated tract. Look for the name and location of the tract operator. A tract operator may be living inside the segment. If the operator lives nearby but still outside the segment, the location of the residence may be marked on the photo or county map. Otherwise, some local inquiries will be necessary to find the operator.

After contacting the operator, introduce yourself and state that you are working with the National Association of State Departments of Agriculture (NASDA) for the U.S. Department of Agriculture (USDA). Explain that the USDA is conducting a yield survey and that this farm has been selected for the survey. Comment on the Objective Yield cover letter on the following page to the operator before the interview starts. Reference the segment image that was sent with the letter.

After reviewing the maps and photos to get an idea of where your samples are located, you are ready to decide which tract operators to contact first. Plan your travel carefully.

Producer Letter Example



United States Department of Agriculture  
National Agricultural Statistics Service  
[Your] Regional Field Office



[Date]

Dear Producer:

For more than 50 years, the Objective Yield Survey has played an integral part in U.S. crop production forecasts. USDA's National Agricultural Statistics Service (NASS) combines field measurements with farmer-reported survey data to publish monthly crop production estimates.

Information from the Objective Yield Survey will help you and other American farmers make informed business decisions on your operations.

The Objective Yield Survey will begin in late April for wheat and late August for corn, cotton, and soybeans. During these timeframes, a NASS representative will visit you and other selected producers to verify crop acreage reported on previous NASS surveys. This visit will take 15 to 25 minutes of your time. With your permission, we will then enter your field(s) at the end of each month during the growing season to collect plant and fruit counts and measurements. Our monthly follow-up visits, if required, will not require your time.

Thank you in advance for your support of our programs and [State] agriculture. If you have any questions or concerns, please contact me at (800) xxx-xxxx.

Sincerely,

[Director's Name]

Director, [Regional] Field Office  
U.S. Department of Agriculture  
National Agricultural Statistics Service

Enclosure

**Mailing Address - City, State Zip**  
**(000) 111-1111 · (000) 111-1111 FAX · [www.nass.usda.gov](http://www.nass.usda.gov)**

USDA is an equal opportunity provider and employer.

The purpose of this survey is to forecast and estimate crop yields based on counts and measurements from sample plots in selected fields. The operator's cooperation will be helpful. A number of the operators have had fields in the Objective Yield Survey in past years, so this will not be new to them. For the new operators, a further explanation of the purpose as outlined earlier in this chapter may be necessary. Remember that the operator is not required by law to participate in the survey.

Interview the farm operator using a conversational tone and answer any questions they may have. If the farm operator is not at home, arrange to call back later. If the operator is not expected in time for you to make a call back before the survey period is concluded, you may obtain the information from some other informed person. In the event no informed person can be found to give the information, note this on the Form A. Do not enter a field to lay out a unit without permission **even if** you know the operator personally. When it is impossible to obtain an interview during the assigned month, continue to attempt to interview the operator through the next survey period.

### Timing of Form A Completion and Setting Up Sample Plots

Once enumerator You will be working from your home, but in close contact with a supervisor. Much of your work will be entered into CAPI or sent to the Lab. Thoroughly review your work for each sample before submitting it. Be sure that all required data are entered. Make notes explaining problems and unusual situations. Always enter the data into CAPI and submit it on the same day the work was done. Also be sure to send the C and E Forms and related plant material on the same day you collect them.

### Turning in Completed Corn Samples

You will be working from your home, but in close contact with a supervisor. Much of your work will be entered into CAPI or sent to the Lab. Thoroughly review your work for each sample before submitting it. Be sure that all required data are entered. Make notes explaining problems and unusual situations. Always enter the data into CAPI and submit it on the same day the work was done. Also be sure to send the C and E Forms and related plant material on the same day you collect them.

When samples are shipped to the laboratory, verify that each sample is properly identified with a completed identification tag fastened to the outside of the bag and record the complete 18 digit tracking number on the Form B that corresponds with the shipment. When you ship the post-harvest sample (Gleaning) to the National Laboratory, send the completed E-form within the same Tyvek.

### Monthly Program

The following table presents survey dates and forms to be completed.

Survey Date	Date Fieldwork Begins	Forms to be Completed
September 1	August 25	A & B <sup>1</sup>
October 1	September 24	B
November 1	October 25	B
After November 1	Just prior to final harvest	B
Post-harvest	Within 3 days after harvest	E <sup>2</sup>

<sup>1</sup> Forms A and B will be completed for all samples for September 1.

<sup>2</sup> Form E will be obtained for every fourth sample.

### **September 1 Survey**

All sample fields will be visited at this time. Complete Form A for each assigned sample. After the interview, you will lay out and make observations on the two sample units. Form B will be used for recording plant counts and measurements.

### **October 1 Survey**

Complete a Form B for all samples remaining to be harvested. If the units for a sample are mature, these units will be harvested and weighed. Corn sample fields to be harvested prior to the survey work week should be visited ahead of the regular survey to complete Form B just before the field is harvested.

### **November 1 Survey**

Complete a Form B for all samples not yet harvested. Sample fields to be harvested prior to the November 1 Survey period should be visited ahead of the regular survey to complete Form B.

### **Final Pre-harvest**

The Form B will be completed for samples not enumerator harvested by the end of the November 1 survey period. As farmer harvest of the sample field nears, close contact must be maintained with the operator. Final preharvest observations should be made as close to harvest as possible.

### **Post-harvest Gleanings Survey**

Form E must be completed within 3 days following farmer harvest. It is important to glean the sample units immediately following harvest to avoid the risk of gleanings being disturbed by birds and rodents, or destroyed by post-harvest tillage operations.

There may be a few instances where extremely bad weather immediately after harvest makes the field inaccessible for a period of time. Close contact should be maintained with the operator to determine when you can enter the field.

**-NOTES-**

## Chapter 2 – Terms & Definitions

### General

Enumerators working on the Soybean Objective Yield Survey should be familiar with the definitions of the terms listed below. To gain the most benefit from training, enumerators should review the definitions of these terms. Appendix A of the "Interviewer's Manual" should serve as a reference for definitions except for the ones detailed below.

### Common Objective Yield Survey Terms

Enumerator	Sample Field
Field	Segment
Lost Sample	Starting Corner
June Area Survey	Supervisory Enumerator
Objective Yield Sample	Survey Statistician
Operator	Tract
	Unit

**June Area Survey** – An acreage survey conducted in early June. The Objective Yield Survey sample is selected from the June Area Survey.

**Narrow Row Soybeans** – Soybeans planted with a planter setting of 18 inches or less between rows.

**Objective Yield Sample** – Consists of two units which are always identified as Unit 1 and Unit 2. Each sample is identified by a unique number.

**Supervisory Enumerator** – A person who has responsibility for a survey field activity of assigned enumerators. They have authority to switch assignments, hire and evaluate enumerators, etc. in coordination with the Survey Statistician.

**Survey Statistician** – Statistician charged with responsibility of a survey - including enumerator training, office edit and processing of forms, and interpreting survey results.

-NOTES-



## Chapter 3 – Form A Interview

### General

The purpose of the Initial Interview (Form A) is to update tract acres planted to Corn since the JAS and obtain acres for harvest. The Form A is used to identify the sample field for the Objective Yield Sample, determine acres to be excluded when locating the sample units, obtain permission to locate sample units, obtain intentions to use pesticide(s) with organophosphorus content, determine if the sample field is irrigated, obtain the seeding rate per acre, and type of seed used in the sample field.

All Form A's in Texas District 1 will be completed during the August 1 survey period. All other Form A's will be completed during the September 1 survey period. Your State field office will provide you with the names and addresses of farm operators to interview, and photos which show the tracts operated by each of these farmers. Each tract is designated with a capital letter.

If all or a part of the original tract has had a change of operator, the Form A acreage still refers to the land area enumerated during the JAS. This allows us to update Corn acreage on exactly the same area of land. You may need to interview the new operator(s) also and obtain acreage changes and permission to enter the sample field. If the operator of the sample field has changed since the JAS, update all of the necessary data on the face of the sample field kit envelope.

### Multiple Samples in Same Tract

Occasionally, more than one sample is assigned to a single tract. In some cases, a single field will contain more than one sample. Your kit envelope contains a complete set of forms for each sample. When two or more samples are selected in a tract, it is not necessary to complete all items on all initial interview forms during the interview.

To avoid asking duplicate questions during the initial interview, complete forms as follows:

**Form A:** Items 1 and 2 - one for each tract.

**Form A:** Items 3 through 10 - one for each sample field.

Shortly after the interview is over, copy the tract data to Form A for additional samples as required.

When you start on a sample, be sure the correct State, POID and sample number are on each form. If not, copy this information from the sample field kit envelope. The date and time the interview started must be recorded at the top of each sample form. Always use military time. The "NASDA Employee's Handbook" has an explanation of the use of military time.

All acreage recorded on the Form A questionnaire must be recorded to the nearest tenth of an acre.  
For example:

<b><u>REPORTED</u></b>	<b><u>ENTER</u></b>
25	25.0
25.25	25.3 (When rounding a 5, always round up.)
25.12	25.1
25.75	25.8 (When rounding a 5, always round up.)
25.68	25.7
None	(-)

**All States:**

You will use Form A for the initial interview of all Corn growers selected. Items 1 and 2 pertain to reported Corn acreage planted or to be planted in the Area Tract. Question 3 pertains to the expected total Corn acres harvested in the Area Tract. Items 4-9 pertain to the sample field.

The name and address of the selected operation you are to contact has been entered on the field kit envelope and Form A. It is very important that you verify this information. Any changes in name and address such as spelling, box or route number, ZIP code, etc., should be corrected on the field kit envelope and on the Form A.

If the operation is known by a farm, ranch or business name, this should also be noted. Listed below are examples of common corrections which should be made:

**Mayes** ~~Hayes~~, Arthur  
Rt. 1  
Red Oakes, YS 46725

Cody, John  
Rt. 1, Box 608  
~~Pinetown~~, YS 54670  
**Bear Poplar, YS 54690**

Sanders, Tom and ~~Rob~~ **Bob**  
No. 2 Cove Road  
Jamesville, YS 46652

Flying J. Ranch  
MGR ~~Merle King~~ **Bob Gray**  
Rt. 1 Box 608  
Edenton, YS 46647

**SOLD** ~~Twin Ranch~~  
MGR Tony Mills  
Evergreen, YS 46104

~~Ridgeview Farms, Inc.~~  
Paul Gum  
R.R. 5  
Elkin, YS 46520  
Farm name - Hill High ~~Ranch~~ **Farm**

The operator may have changed the acreage of Corn to be planted since intentions were reported during the June Area Survey. This will mean that Item 2 will differ from Item 1. Never change Item 1, but write notes so that the office staff understands the situation.

**Example 1:** The operator does not currently operate the entire acreage reported as Corn in June. For example, part or all of the land was sold, leased, or rented to someone else.

Procedures:

1. Include the land that has changed hands in with the original operator's acreage.
2. Select the sample field(s) based on the total acres reported in June. If the sample field(s) is controlled by the original operator, obtain permission to enter the field. If the sample field is now operated by a different person, you will need to contact this new operator for permission.

- Obtain the name, address and phone number of the new operator regardless of whether you need to make contact on this survey.

**Example 2:** The operator currently operates more land than reported in June.  
The additional land, bought or leased, may have Corn planted on it already.

Procedures:

- Exclude this new acreage.
- Select the sample field(s), and proceed with interview.

**Example 3:** The operator still operates the land reported in June and has not acquired additional acreage. The difference between Item 1 and Item 2 is due to:

- A respondent or enumerator error on the June Agricultural survey
- The actual planted acres changed from the intentions reported in June.

**Questionnaire Procedures:**

Procedures:

- Record the date on the front page of the Form A.
- Do not change Item 1, even if you determine that the figure is in error. Write notes.

Earlier this season, the number of corn acres you planted or intended to plant for all purposes on all the land you operate in the tract was: .....

JUNE PLANTED ACRES
DO NOT CHANGE

The total acres planted in the grower's tract as identified on the face page has been entered in Item 1. Do not change this entry for any reason.

**NEBRASKA and KANSAS ONLY:** *The Corn Objective Yield Survey for Nebraska and Kansas is divided into an irrigated and non-irrigated sample. Fields have been designated as irrigated if any part of the field was listed as irrigated in the June Area Survey. If the sample is non-irrigated, only non-irrigated fields in the tract are listed in Table A. Any additions or corrections to Table A should be for non-irrigated fields only. Similarly, for an irrigated sample only irrigated fields in the tract are listed in Table A and additions or corrections should be made for tract irrigated fields.*

Read the first sentence in Item 1 and show the aerial photo to the operator to refresh his memory. Tract boundaries and tract codes are shown in blue on the aerial photo. Give the operator time to get oriented to the photo.

- Now I want to update this corn acreage information. What is the current number of corn acres you planted for all purposes on all the land you operate in the tract?..... **ACRES**
- What are the total acres of corn to be harvested for grain or seed on all the land you operate in the tract? (If total equals zero, end interview)..... **ACRES**

	105
	102

To Verify, what are the total tract acres of Corn planted or to be planted on the land you operate?

Now, I need to identify one (or more) of your corn field(s) in the tract and get their acreage.

Notes:

- For the Sample Field(s) in the tract, complete Table A for the corn field(s) based off the cardinal directions indicated on the label (e.g., northern most field)
- Select corn field regardless if the field is intended to be harvested for grain/seed or other use.

This statement will serve as an introduction to Table A. The reason for mapping the sample fields is to have a way of finding the sample field. Complete the table based on lowest sample number to largest sample number.

**Table A**

SAMPLE NUMBER and DIRECTION	TOTAL ACRES IN FIELD	ACRES in USE or CROPS OTHER THAN CORN to be HARVESTED for GRAIN or SEED <i>(For example: silage, ditches, fence rows, waterways, roads, other crops, etc.)</i>		LOCATION DESCRIPTION/ INTERSECTION OF FIELD <i>(E.g., landmarks, features, street intersections)</i>
		USE	ACRES	
1	2	3	4	5
	. ____		. ____	
	. ____		. ____	
	. ____		. ____	
	. ____		. ____	
	. ____		. ____	
	. ____		. ____	

**Draw the Corn field on a grid map.**

The purpose of the grid is to help locate the Corn sample. You will want to start by drawing the tract in the grid. Next, identify the Corn field in the tract. Have the operator describe any roads, landmarks, and natural boundaries that will help you identify and keep track of the fields. Use the grid to sketch the roads, landmarks, etc.. Use of a county highway map in conjunction with the grid map may also help you as you and the operator identify the sampled field. Scale is not important; however, the relative location is critical.

If you have problems drawing the grid map, call your Survey Statistician for instructions.

**Sample Number and Direction**

The samples will be labeled with a direction. If a sample is marked with the direction “N” or North, have the operator identify the northern most field in the tract. If two fields are the same distance in the labeled direction, select the field furthest clockwise. So if there are two field that are the same distance North, select the field furthest to the East for the sample. Similarly, if the selected direction is West, select the field that is furthest North. Select one Field per sample until there are no more fields, then go back to the first field and continue the same process until there are no more samples.

**Required entries in Table A, Columns 2-5.**

For each field, record the data required in Table A:

1. Total Acres in Field (Column 2): Record all acreage in the field. Be sure to match the sample number assigned on the grid to the sample number in Table A.
2. Acres in Other Uses: Columns 3 and 4 are used to indicate any areas in the field from which Corn will not be harvested. If the field was completely tilled up and not replanted to Corn, the acreage would be recorded in Columns 3 and 4.
3. LOCATION DESCRIPTION/INTERSECTION OF FIELD (Column 5): Now record landmarks, features, and street or road intersections to help identify where the field is located.

The direction variable will determine in which field the sample will be laid out. One sample is selected for one field. There will only be one sample per field listed in Table A, unless there are fewer fields in the operation than the number of samples selected for the operation. After selecting the sample field, you will complete the interview by asking Items 3-8 for each sample field using Form A-1.

The remaining questions on Form A refer specifically to this field assigned to the sample number identified on the front page of the Form A.

If the sample field is already harvested, do not select an alternate field.

All questions below apply to this SAMPLE.

3. For the Sample Field, subtract Column 4 from Column 2 for the total acres of corn to be harvested for grain or seed. Report these acres here:..... ACRES

Copy the sample field number and its acres to be harvested for grain in the appropriate places in Item 3. Make sure the farmer understands which field is the sample field. It may be necessary to point out the field on the ground or describe its location in terms of other physical features. In all cases, the number of acres entered in Item 3 should agree with the acreage for that same field as entered in Table A.

4. What was the planter row width setting?..... INCHES

If corn is planted in twin rows (narrow/wide/narrow arrangement), the measurement recorded in Item 107 is the from the center of one pair of twin row to the center of the next pair of twin rows. For example, a field with 6-inch twin rows and a 24-inch middle row would record 30 in item 107.

5. On what date was planting completed in this corn field?..... MM DD

In Item 5 record the date (month and day) that planting of the sample field was completed. If the field was replanted, record the date of the last planting. If the date is not known, use the farmer's best estimate.

**Kansas and Nebraska Only for Item 6**

6. Has this field been (or will it be) irrigated?    1  Yes    3  No    2  Don't Know

CODE

Kansas and Nebraska need to determine if the operator has irrigated, or plans to irrigate, any portion of the sample field. A code 1 or 3 must be entered in the 104 box. A code 2, don't know, should only be used if the farmer is unavailable for an interview.

7. With your permission I will go out to the field and mark off two small plots to be used in making stalk and ear counts. I will return to the plots each month until harvest to make counts and measurements, and harvest and weigh a few ears. Would that be all right?

Yes - Continue. (Inform respondent what day/approximate time you intend mark off two small plots to be used in making stalk and ear counts)

No - Conclude interview and return all forms.

The purpose of Item 7 is to obtain and record the farmer's cooperation to let you make the pre-harvest objective yield counts and the post-harvest gleanings. Use a conversational tone in explaining your monthly visits to the field and answer any questions which the farmer may have about the field work.

8. Have you or will you apply pesticides with organophosphorus content to the sample field?

Yes

No

Don't know

If yes, enter latest application date \_\_\_\_\_ and name of pesticide \_\_\_\_\_.

The purpose of Item 8 is to check if the operator has applied or intends to apply pesticides with organophosphorus content to the sample field. If yes, be certain to copy the information to the sample kit envelope and the Form B. Check back with the operator during future visits regardless of the answer given for Item 8. The operator may need to spray if an infestation should occur.

9. Where should I leave the corn picked from the units? \_\_\_\_\_

(Copy to the sample kit envelope the location where the operator wishes you to leave the corn.)

Ask the farmer if the Corn you pick can be removed from the field for weighing and not returned. This question is asked so you can weigh the Corn at home in a more controlled setting. Weighing at home will give you more accurate results plus extend the life of the scales.

If the operator wants the Corn weighed and left in the field, this question is asked to determine where the operator wants you to leave the Corn.

10. Do you intend to harvest this field as high moisture corn?  
(High moisture corn is defined as corn with moisture content of 30 percent or more.)

Yes

No

Don't know

This will alert you if a producer plans to harvest the grain as high moisture corn. This information should be transferred to the kit envelope and Form B. It will serve as a guide and help reduce the number of lost samples. High moisture corn is defined as corn with a moisture content of 30 percent or more.

**NOTE:** If this is a gleaning sample, tell the operator "After harvest, I will also lay out two small plots to determine harvest loss."

For Post-harvest samples tell him you would like to glean the sample fields to determine harvest loss. If the response is no, conclude the interview and return all forms to the State office. The Form E will be completed if permission is granted. Otherwise send all forms to the State office.

11. Respondent Name: \_\_\_\_\_

PLEASE CHECK THE FOLLOWING:

- Review the form for completeness
- Sign name
- On the kit envelope, record operator's  
Telephone number  
Expected harvest date  
Pesticide intentions (Item 8), and  
Location to leave corn (Item 9)

Enumerator Number	190
Supervisor Number	191
Evaluation	193

12. Enumerator Name: \_\_\_\_\_

STATUS CODE	180
-------------	-----

It is important that you maintain contact with the operator so you will know when the sample field will be harvested. This knowledge on harvest will enable you to obtain the final pre-harvest observations as near harvest as possible, and to obtain post-harvest gleanings and interview within three days after harvest.

Answer all questions the farm operator has about the role of the State Agricultural Statistics Service. If the operator is interested in obtaining Corn production estimates, Enter the e-mail address in the space provided. The State office will see that the information is sent. The operator can access the full report at [www.nass.usda.gov/results](http://www.nass.usda.gov/results).

You should leave the farm operator with all questions answered and in a cooperative mood. Remember, the operator may be contacted again for another survey and your actions will greatly influence a willingness to cooperate.



**Form A Completion Checklist:**

Follow the checklist below after you have interviewed the farmer but before you make the field counts:

1. If more than one field is sampled in the tract, copy the tract data, Items 1-2 including Table A, to all Form A's. Items 3-10 refer to the sample field only.
2. Copy the information in Items 9 and 10 to the kit envelope; also copy Item 9 to Form B.
3. Check any notes you have made on the forms to make sure they are clear. If it was impossible to obtain Form A, note this on the face of the form and on the front of the kit envelope. Plan to interview the operator during the next survey period to obtain permission to lay out the sample units and obtain the cropping practices data.
4. Review Form A for completeness. Enter the Data into the iPad. Follow your Regional Field office instructions on disposition of the form.
5. If the operator will not cooperate and provide an interview, you should still record the date and times that you attempted the interview.

## FORM A CORN YIELD SURVEY - 2024

OMB No.: 0535-0088  
Approval Expires: 7/31/2026  
Project Code: 104  
Survey ID: 1964



Please make corrections to name, address and ZIP Code, if necessary.

Date: \_\_\_\_\_

---

The information you provide will be used for statistical purposes only. Your response will be kept confidential and any person who willfully discloses ANY identifiable information about you or your operation is subject to a jail term, a fine, or both. This survey is conducted in accordance with the Confidential Information Protection and Statistical Efficiency Act of 2018, Title III of Pub. L. No. 115-435, codified in 44 U.S.C. Ch. 35 and other applicable Federal laws. For more information on how we protect your information please visit: <https://www.nass.usda.gov/confidentiality>. Response to this survey is voluntary.

According to the Paperwork Reduction Act of 1995, an agency may not conduct or sponsor, and a person is not required to respond to a collection of information unless it displays a valid OMB control number. The valid OMB number is 0535-0088. The time required to complete this information collection is estimated to average 20 minutes per response, including the time for reviewing instructions, searching existing data sources, gathering and maintaining the data needed, and completing and reviewing the collection of information.

---

Earlier this season you gave a representative from our office information about the corn acreage on your farming operation. We are now collecting information to help determine corn production in (Your State) and the United States.

Earlier this season, the number of corn acres you planted or intended to plant for all purposes on all the land you operate in the tract was: .....

JUNE PLANTED  
ACRES

--

DO NOT CHANGE

- Now I want to update this corn acreage information. What is the current number of corn acres you planted for all purposes on all the land you operate in the tract?..... ACRES
- What are the total acres of corn to be harvested for grain or seed on all the land you operate in the tract? (If total equals zero, end interview)..... ACRES

105
-----

102
-----

Now, I need to identify one (or more) of your corn field(s) in the tract and get their acreage.

Notes:

- For the Sample Field(s) in the tract, complete Table A for the corn field(s) based off the cardinal directions indicated on the label (e.g., northern most field)
- Select corn field regardless if the field is intended to be harvested for grain/seed or other use.

**Table A**

SAMPLE NUMBER and DIRECTION	TOTAL ACRES IN FIELD	ACRES in USE or CROPS OTHER THAN CORN to be HARVESTED for GRAIN or SEED <i>(For example: silage, ditches, fence rows, waterways, roads, other crops, etc.)</i>		LOCATION DESCRIPTION/ INTERSECTION OF FIELD <i>(E.g., landmarks, features, street intersections)</i>
		USE	ACRES	
1	2	3	4	5
	. ____		. ____	
	. ____		. ____	
	. ____		. ____	
	. ____		. ____	
	. ____		. ____	
	. ____		. ____	

FORM A: CORN - Continued

All questions below apply to this SAMPLE.

3. For the Sample Field, subtract Column 4 from Column 2 for the total acres of corn to be harvested for grain or seed. Report these acres here:..... ACRES
4. What was the planter row width setting?..... INCHES
5. On what date was planting completed in this corn field?..... MM DD

**Kansas and Nebraska Only for Item 6**

6. Has this field been (or will it be) irrigated? 1  Yes 3  No 2  Don't Know CODE

7. With your permission I will go out to the field and mark off two small plots to be used in making stalk and ear counts. I will return to the plots each month until harvest to make counts and measurements, and harvest and weigh a few ears. Would that be all right?
- Yes - Continue. (Inform respondent what day/approximate time you intend mark off two small plots to be used in making stalk and ear counts)
- No - Conclude interview, enter data in to CAPI, and return all forms.

8. Have you or will you apply pesticides with organophosphorus content to the sample field?

Yes  No  Don't know

If yes, enter latest application date \_\_\_\_\_ and name of pesticide \_\_\_\_\_.

9. Where should I leave the corn picked from the units? \_\_\_\_\_

(Copy to the sample kit envelope the location where the operator wishes you to leave the corn.)

10. Do you intend to harvest this field as high moisture corn?  
(High moisture corn is defined as corn with moisture content of 30 percent or more.)

Yes  No  Don't know

NOTE: If this is a gleaning sample, tell the operator "After harvest, I will also lay out two small plots to determine harvest loss."

11. Respondent Name: \_\_\_\_\_

PLEASE CHECK THE FOLLOWING:

- Review the form for completeness
- Sign name
- On the kit envelope, record operator's Telephone number  
Expected harvest date  
Pesticide intentions (Item 8), and  
Location to leave corn (Item 9)

Enumerator Number	<input type="text" value="190"/>
Supervisor Number	<input type="text" value="191"/>
Evaluation	<input type="text" value="193"/>

12. Enumerator Name: \_\_\_\_\_

STATUS CODE

**Survey Results:** To receive the complete results of this survey on the release date, go to:  
[www.nass.usda.gov/results](http://www.nass.usda.gov/results)

To have a brief summary emailed to you, please enter your email address:
1095

Operation Email: (if different from above)

Operation Phone:

9937	9936 ( ) - _____	check if cell phone <input type="checkbox"/>
------	---------------------	--

Respondent Name:

Respondent Phone (if different from above)

9912	9911 ( ) - _____	check if cell phone <input type="checkbox"/>	9910	MM	DD	YY
			Date:	__	__	__

**This completes the survey. Thank you for your help.**

**-NOTES-**

## Chapter 4 – Unit Location

### General

Two units are laid out for each sample at the time of the initial interview. These units will be used each month during the growing season to make plant and fruit counts. The units are located and laid out according to specific procedures to assure randomness. First locate the selected sample field using the grid map and County and State maps.

For corn samples, immediately after completing the Form A-1 interview and before going to the sample field, determine the paces to be used for locating the units. To do this, find the appropriate field size on the labels on the back of your field kit envelope. The acres of corn for harvest in Item 3, Form A-1 determines which column is to be used. Circle the unit location numbers under the appropriate field size on the labels. The rows line corresponds to the paces along the edge of the field and the paces line corresponds to the paces into the field. Copy these unit location numbers to all Form B's and the Form E for the sample.

For subsequent sample locations, use the next set of unused labels. Circle the numbers as they are used. There is one set of labels for every sample selected for an operation. Unit locations have been entered by the State office for all corn samples.

Record the date in the space provided at the top of the Form B.

### Location, Layout and Markings

The principle of unit location is to allow the units to fall anywhere within the field boundaries (excluding acreage deducted from Form A-1) with equal probability. See examples in Special Problems (Chapter 5). The point of entry into the field or starting corner will be the first corner of the field which is reached when approaching the field and which can qualify as a starting corner.

#### Starting point for additional samples in field

If the field has been selected for more than one sample, the second (or third) closest corner to the starting corner will be used as the starting corner for the second (or third) sample number. If and only if the field has no definite corners, enter the field from the point which is most accessible by car. If the field has been selected for more than one sample and the field has no definite corners, the next most accessible point will be used as the starting corner for the second sample, and so on.

#### Locating Unit 1

The following steps outline procedures for locating and laying out sample units.

- Step 1:** Mark the starting corner so it will be clearly visible on later visits. Tie a piece of plastic flagging ribbon to a fence or nearby object or drive a large stake in the ground and attach the ribbon. Make a note of the location and type of marking used on the kit envelope field sketch.
- Step 2:** Walk along the end of the rows until you have counted the number of rows indicated for Unit 1. This is Row 1 of Unit 1. The next row in the direction of travel is Row 2 of Unit 1. Tie a piece of flagging ribbon to the first stalk in Row 1. This will help you find the same row on subsequent visits.

- Step 3:** Walk the required number of paces into the field between Row 1 and Row 2. Start the first pace one and one-half feet outside the plowed end of Row 1. This starting point applies even if plants are not growing to the plowed edge of Row 1.
- If you cross any of the areas deducted as "Other Uses" on the Form A, stop counting rows or paces at the start of each area and resume counting at the other side. Any blank or unplanted areas in the field that were not deducted should be included in the row and pace count.
- Step 4:** After the last pace, lay the dowel stick down so that it touches the toe of your shoe, across Row 1 and Row 2, and at right angles to the rows. Lay out Unit 1 in the direction of travel.
- Step 5:** Anchor the zero end of the 50 foot tape just beyond the dowel stick and next to the plants in Row 1. Work from the outside of the unit. The zero end of the tape must be anchored firmly and close to the ground so it will not move when measurements are made. Mark the sample number on a florist stake and insert it at the anchor point.
- Step 6:** Insert a florist stake, identified "U1 - R1" for Unit 1 and Row 1 exactly 5 feet from the anchor point.
- Rule 1:** If a plant emerges from the ground exactly at the **starting stake**, include that plant in the unit.
- Step 7:** Insert a stake exactly 20 feet from the anchor point. These stakes should be placed straight up and down with the flat side at right angles to the row and as close as possible to the center of plants in the row.
- Rule 2:** If a plant emerges from the ground exactly at the **ending stake**, exclude that plant from the unit.
- Step 8:** Identify the first plant in the unit. Tie a piece of flagging ribbon to mark plant for future visits. Use Rule 1 at the starting stake in each row.
- Step 9:** Anchor the 50 foot tape just beyond the dowel stick and next to the plants in Row 2. Do not place a florist stake at the Row 2 anchor point.
- Step 10:** For Row 2 insert a florist stake 5 feet from the anchor point. Mark the starting florist stake as follows: "U1 - R2" for Unit 1, Row 2. Do not move the florist stakes; they define the 15-foot count unit.
- Step 11:** Insert a florist stake exactly 20 feet from the anchor pin.
- Step 12:** Identify the first plant in the unit. Tie a piece of flagging ribbon to mark the first plant for future visits. Use Rule 1 at the starting stake in each row.
- Step 13:** Identify the first plant in the unit.
- Optional:** Tie a piece of flagging ribbon across Row 1 and Row 2 at the start of the buffer zone to mark the unit across Row 1 and Row 2 for future visits.



**Example:** Unit 1 located 6 rows along the edge of the field and 5 paces into the field:

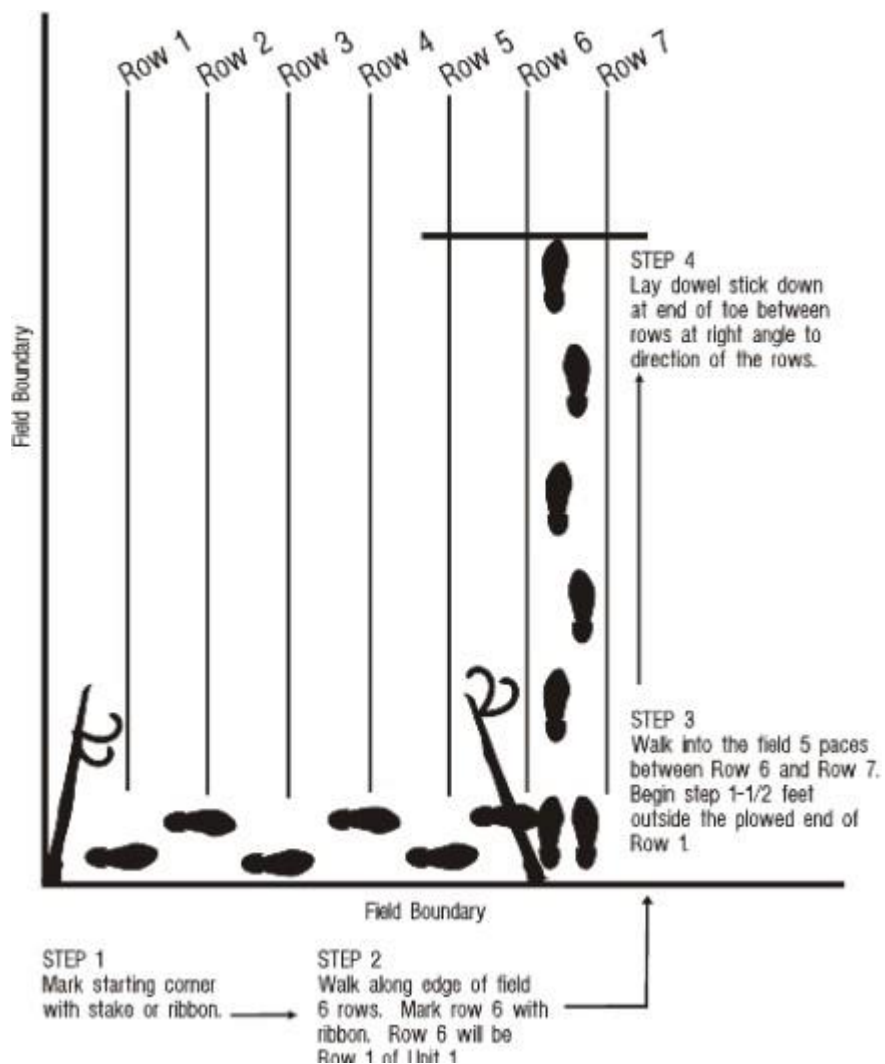

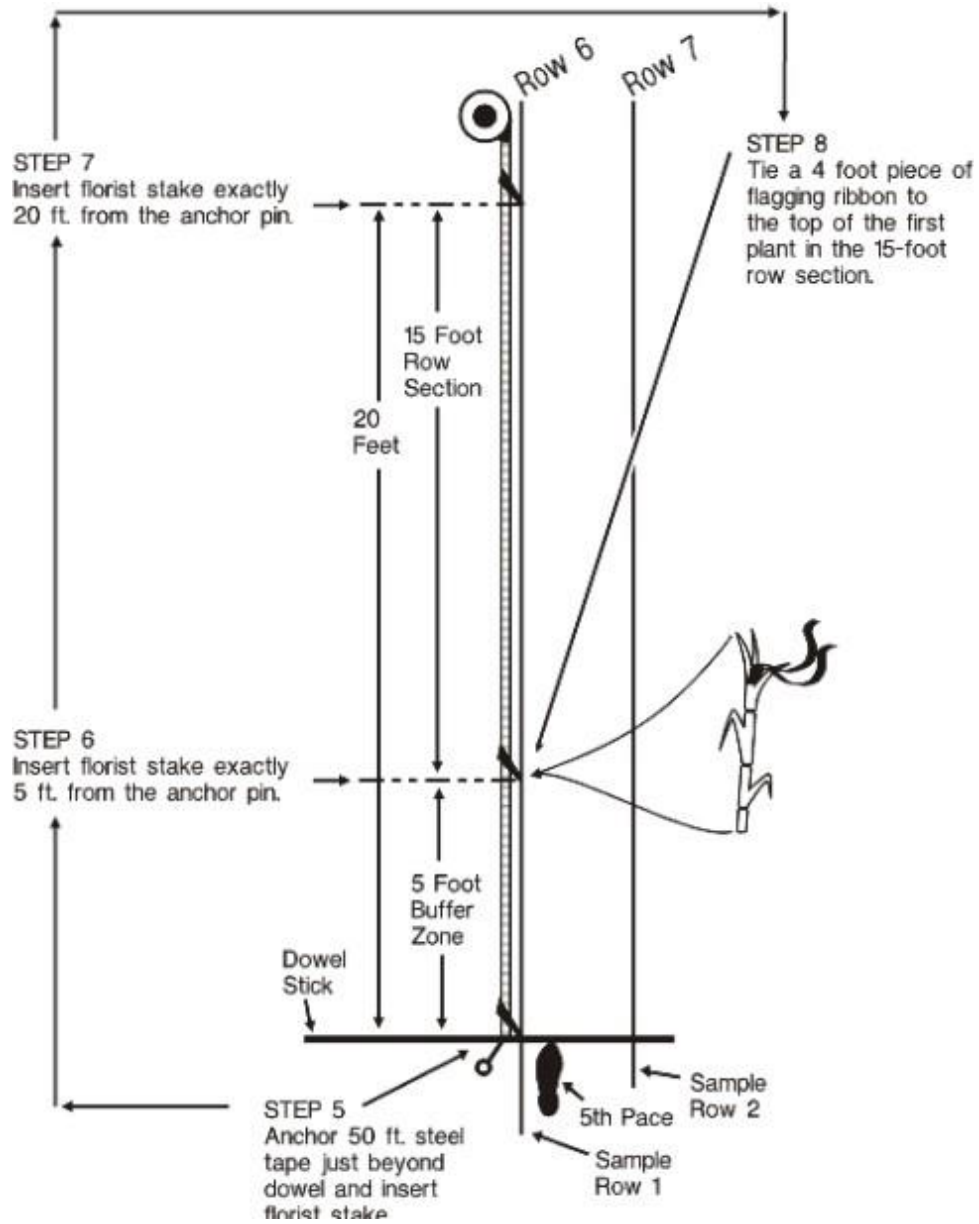

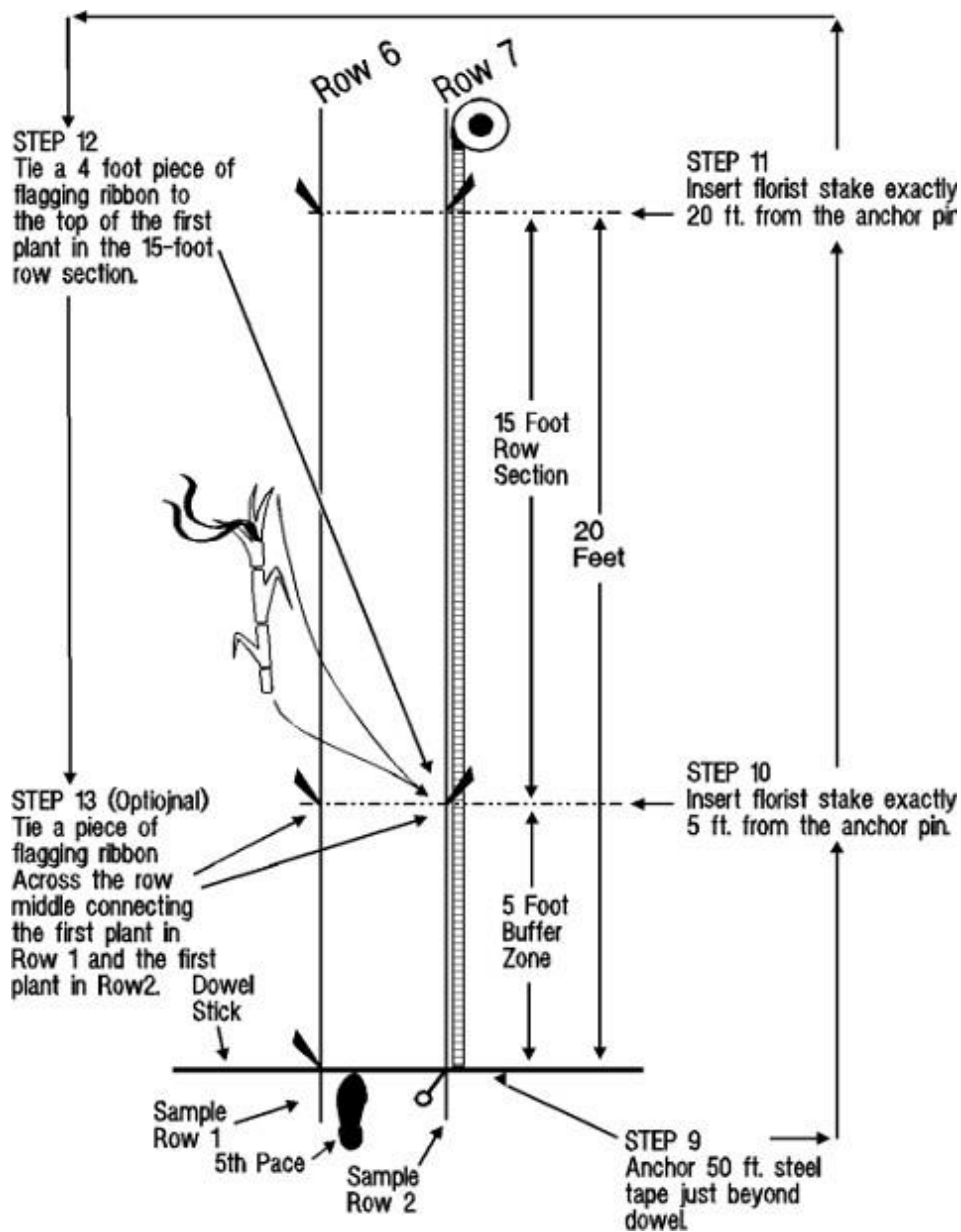

### Locating Unit 2

After completing the Form B observations in Unit 1, start from the row for Unit 1 and walk 30 more rows in the same direction that you were traveling when you located Unit 1. Then turn and walk into the field for the number of paces from Unit 1 PLUS 30 more paces. At that spot, locate, lay out and mark Unit 2. For example, if Unit 1 was 50 paces into the field, Unit 2 should be 80 paces into the field (50+30). Remember to stop counting paces when walking through a deducted area (refer to Table A, Form A-1).

The same steps apply in laying out Unit 2 as Unit 1 except florist stakes will be marked U2-R1 and U2-R2.

### Preparing Sketch of Sample Units

After completing the work for Unit 2, draw a field sketch on the sample field kit envelope. The sketch should be large and detailed so that the starting corner and units can be located on later visits.

### Twin Row Procedures

In a twin row planting configuration, corn is planted in paired rows, usually 7 or 8 inches apart, on 30-inch centers (*narrow/wide/narrow arrangement*). In cases where flood irrigation practices are in use they will be planted in a formed seedbed, elevated above the wider irrigation furrows. The twin row configuration presents challenges for counting rows, determining row space measurements, and recording plant & fruit counts for the purposes of the Objective Yield Surveys.

### Twin Rows Sample Unit Location

Each twin row sample unit is comprised of 2 pairs of twin rows. When counting rows along the field's edge to locate the first row of a sample unit, count the pairs of twin rows as individual sample unit rows.

When counting twin rows planted on formed beds, be sure to count only the pairs of twin planted rows and not count the formed beds. This is the best practice to prevent miscounting in cases where more than one pair of twin rows are planted on the same formed bed or when bed widths are non-uniform.

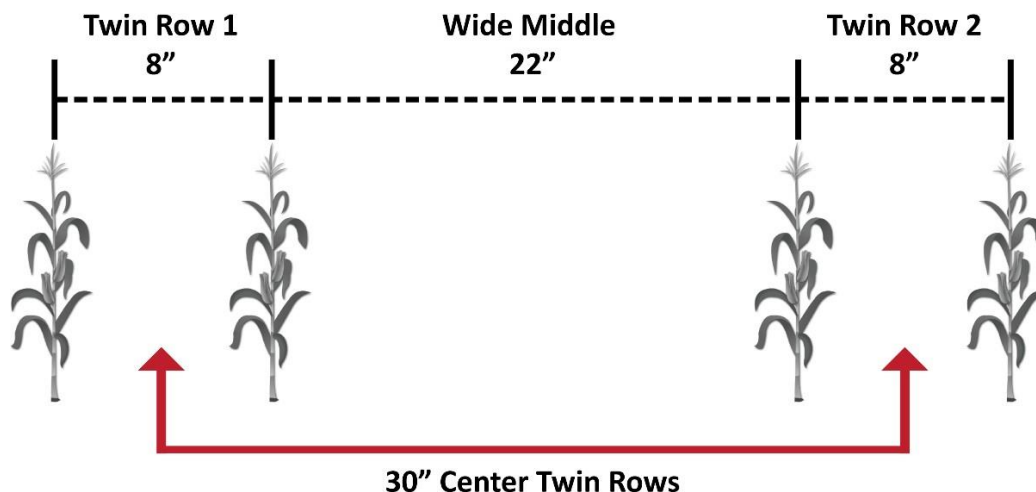

### **Twin Row Space Measurements**

In the direction of travel, measure from the center of the first pair of twin rows in the selected row to the center of the second pair of twin rows (*across 1 wide middle rows*). Continue the measurement from the center of the first pair of twin rows further on to the center of the fifth pair of twin rows (*across 4 wide middle rows*).

### **Laying Out Twin Row Units**

Twin row units will be laid out using the same practices used when measuring fields planted in a uniform, single row configuration. The only difference between the single and twin row units is the twin row unit uses the plants in the two twin rows for each unit row (4 individual rows of plants per sample unit = 8 individual rows per sample). Mark and flag all twin row sample units with the inclusion of the twin row.

### Special Problems in Laying Out Units

#### Seed Corn Fields

Procedures for laying out units in seed corn fields are the same as any other corn field.

#### Locating a Unit in Fields with End Rows

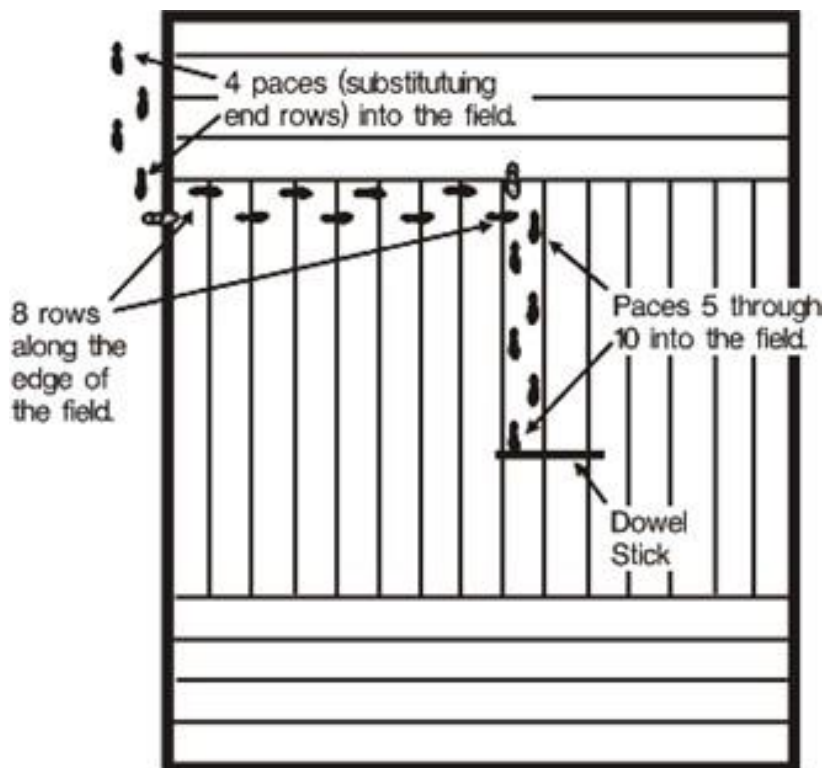

If a field has end rows, make a note of how many there are, but do not include them in count of rows. To begin counting "rows along the edge of field", walk along the ends of the regular rows inside the field, counting them to find row 1 of unit 1.

After finding row 1 of the unit, start pacing into the field from the end of row 1; Count the end rows as paces. For example, if there are 4 end rows, start your pace count with 5 and continue into the field the required number of paces.

If the pace count is less than the number of end rows, the unit will be laid out in the end rows. If, in this example, the number of paces is exactly 4, then row 1 of the unit would be end row 4 and row 2 of the unit would be end row 3. A unit will be laid out in end rows when the number of paces is less than the number of end rows. When the unit falls in end rows, always lay out the unit away from the starting corner.

**Blank Area that was Deducted**

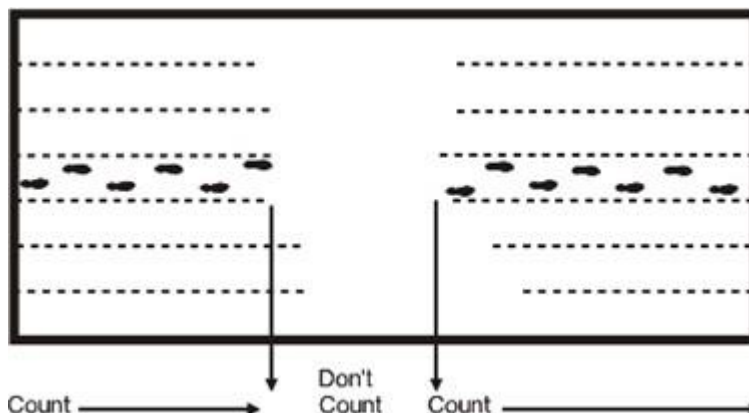

Sample units are never located in "excluded" areas or in any other areas reported as acreage in "Other Uses" in Table A of Form A.

If, when counting paces into the field, you cross an area which was deducted from the acreage to be "harvested for grain" stop the count at the start of the area and resume the count on the other side.

**Blank Area or Other Crop Not Deducted**



If you cross a blank area which was not deducted from the acreage to be harvested for grain on Form A, continue to count paces through this area. If the last pace falls in this blank area, the unit must be laid out even if no plants are present.

If only one unit falls in a blank area, continue to make monthly counts on the other unit. Enter zeros in the appropriate box for the unit located in a blank area.

In case both units fall in a blank area (no plants standing in either of the sample rows) which was not deducted from the net acreage standing for grain (Table A) the units will be laid out. Note for future reference on the kit envelope that the units fell in a blank area, complete a Form B entering zeroes where appropriate. Note on the Form B that both units were blank and return all B forms to the State office.

### Bounce Back Techniques

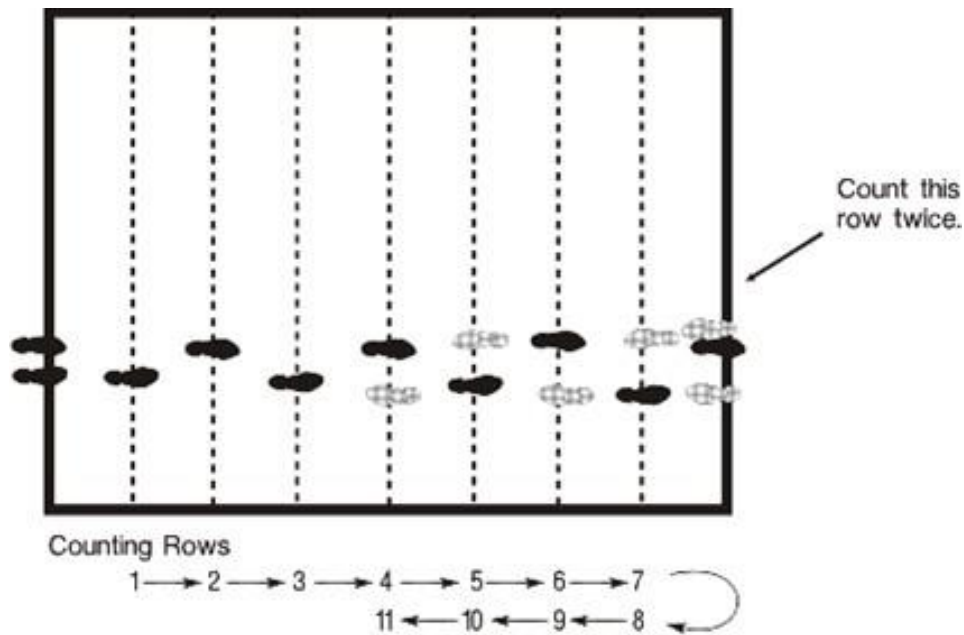

In counting rows, if you reach the opposite edge of the field and still have not counted the designated number of rows, turn around and walk back in the direction from which you came until the required number is counted. The last row is counted twice--once as you go out of the field and again as you start back into the field. Always take the next row in direction of travel for Row 2. If row 1 of the unit falls on the last row in the field, then row 2 becomes the next row in the direction of travel after bounce back.

In counting paces, if you reach the end of the field and still have not counted the required number of paces, turn around and walk back in the direction from which you came until the required number of paces is counted. Lay down the dowel stick and lay out the unit in the same direction that you were traveling when you counted the last pace.



**Rows Change Directions**

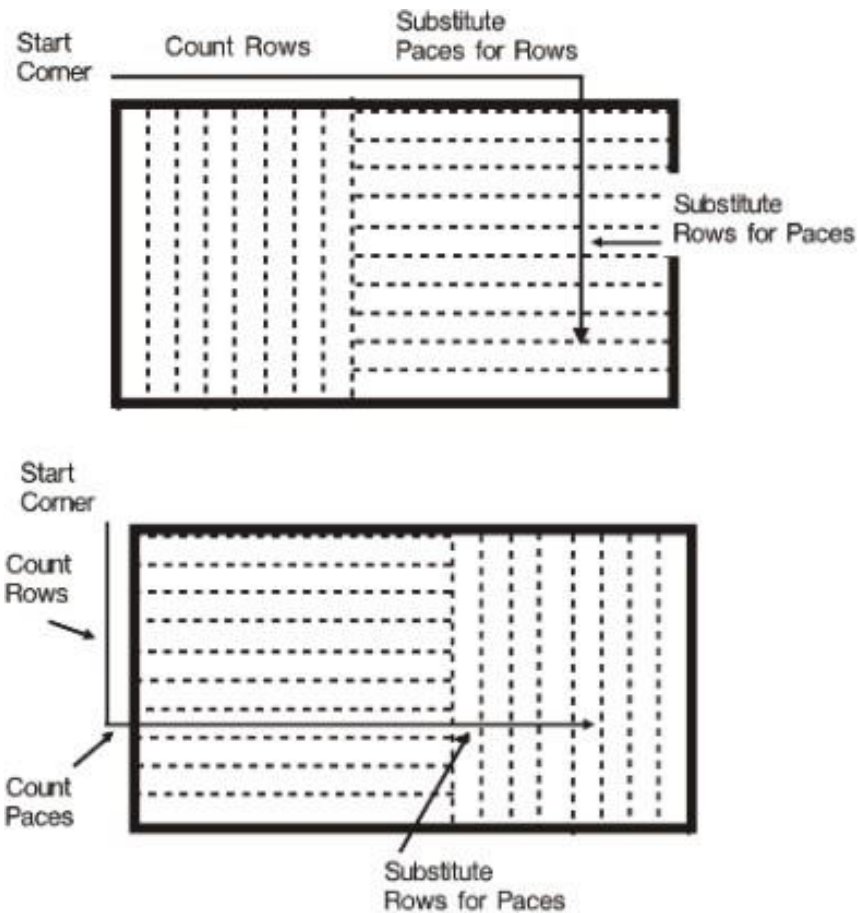

In counting rows, when the direction of the rows changes at right angles, or when there is no definite direction to the rows, or when it is impossible to count rows, continue in the same direction along the edge of the field and substitute an equal number of paces for rows. Make a note of such changes on the form and on the sample field kit envelope opposite the sample number.

In counting paces, when the direction of the rows changes at a right angle, substitute an equal number of rows for paces. When laying out units and rows change direction, always lay out the unit away from the starting corner.

### Locating Units in Odd Shaped Fields

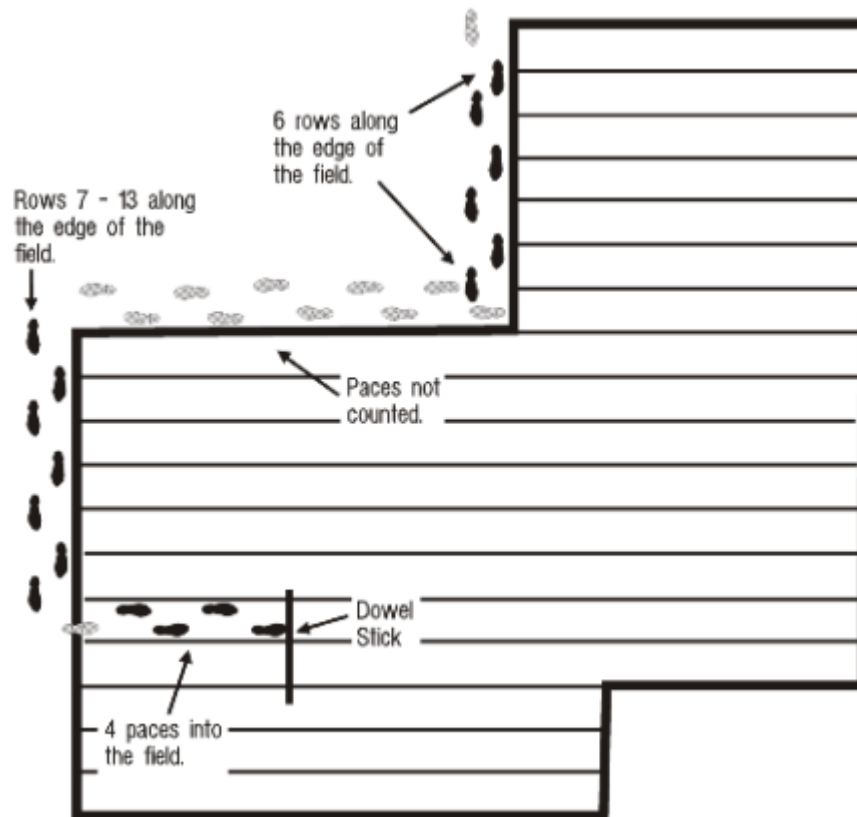

When locating units in odd shaped fields the same rules apply that were discussed previously. In the illustration above, stop counting when walking to the beginning of row 7.

When laying out samples in odd-shaped fields the main things to remember are: (1) starting corner, (2) direction of travel, and (3) deducted and non-deducted areas.

**Fields with Blocking and Blank Area Not Deducted**

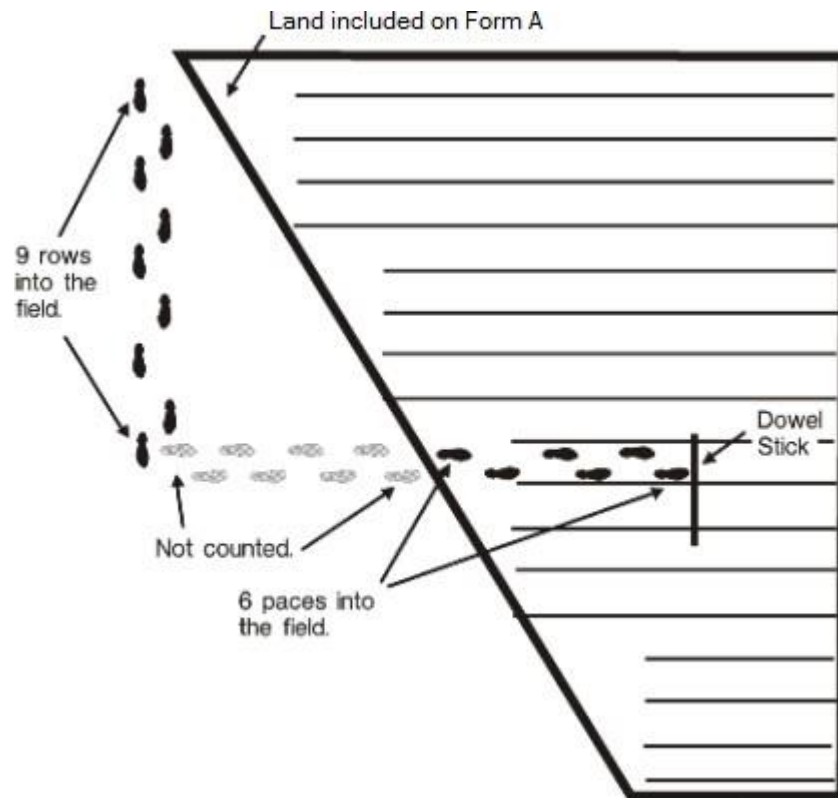

With the use of large equipment there may be a blocking effect along a slanting field boundary. In the case illustrated above the distance from the actual start of plants in row 9 might be 50 feet or so from the starting point of row 8.

If the blank area was not deducted from the acreage for harvest on the Form A, the unit would be laid out 6 paces into the field starting 1.5 feet from the plowed edge of the field. Field row 9 would still be unit 1 row 1 and row 10 would be unit 1 row 2.

**Fields with Blocking and Blank Area Deducted**

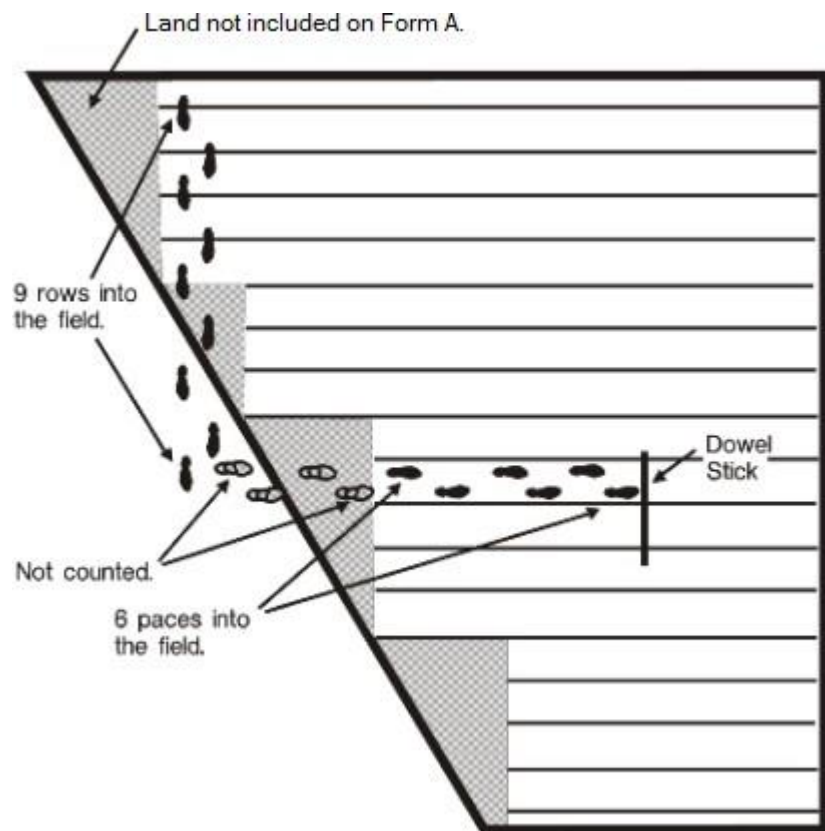

Assume a row and pace count of 9 and 6, respectively. Row 9 is the selected row of the unit. If the blank area was deducted from the acreage for grain on the Form A, the unit would be laid out 6 paces into the field from the beginning of row 9.

**Units Fall beyond End of Field**

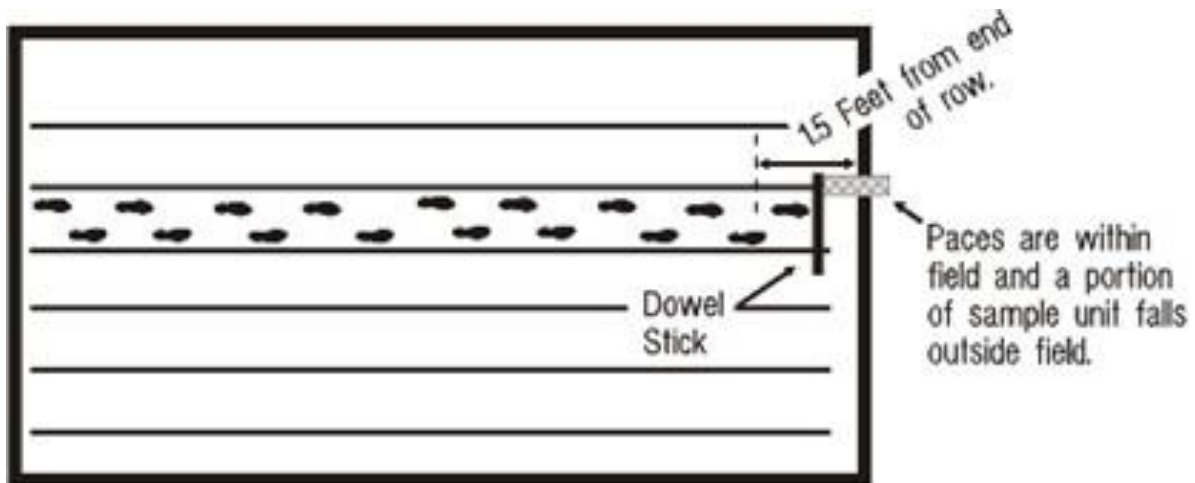

If a unit falls partially outside the field after you have taken your last pace, pick up the dowel stick and move back until the end of the unit is 1.5 feet from the plowed edge of the field and lay out the unit.

If the unit falls partially in end rows after you have taken your last pace, pick up the dowel stick and back up until the unit is 1.5 feet from the center of the plants in the first end row. (**Do not lay out a unit across rows**).

This also applies when a unit falls partially within an area which was deducted from the acreage for harvest as grain on the Form A. Move the unit back until it is located wholly on acreage planted for grain with the endpoint of the unit 1.5 feet from the deducted area.

**Center Pivot Fields - Starting Corners**

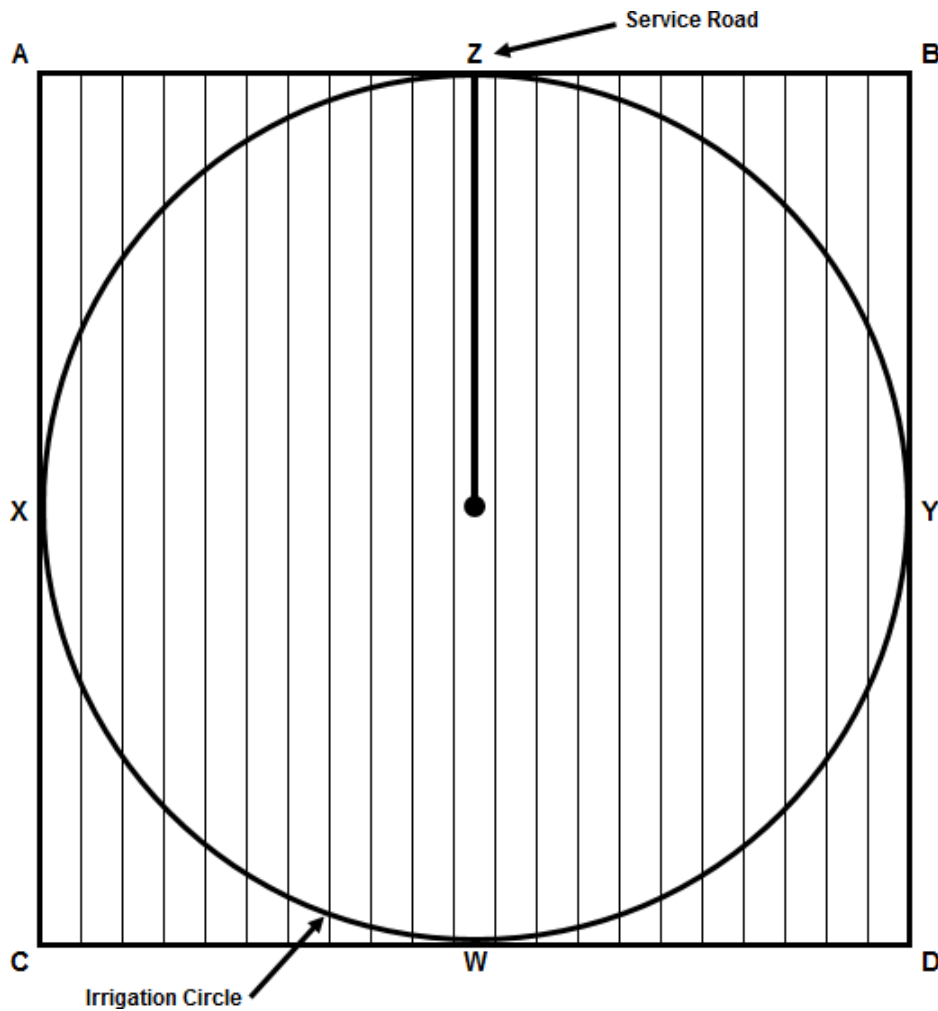

**Scenario 1**

The entire field including corners, is planted to corn for grain in uniform rows. For all States except Nebraska and Kansas, the correct choices for starting corners are A, B, C and D even though the access road is at point Z. In most cases, the most accessible starting corners will be A and B since the service road can be accessed from the same side of the field. Paces along the edge of the field and into the field will be counted in the usual manner. Because Nebraska and Kansas differentiate between irrigated and non-irrigated plantings for corn, the correct starting corner for this field in Nebraska and Kansas would be point Z. While standing at point Z, unit 1 will be laid out to the right (towards point X). After completing the Form B observations in Unit 1, start from the last pace required for Unit 1 and walk 30 paces parallel with the longer side of the field and in the same direction that you were traveling when you located Unit 1. Then turn at a right angle and walk 30 more paces into the field, to locate, lay out and mark Unit 2.

Center Pivot Fields

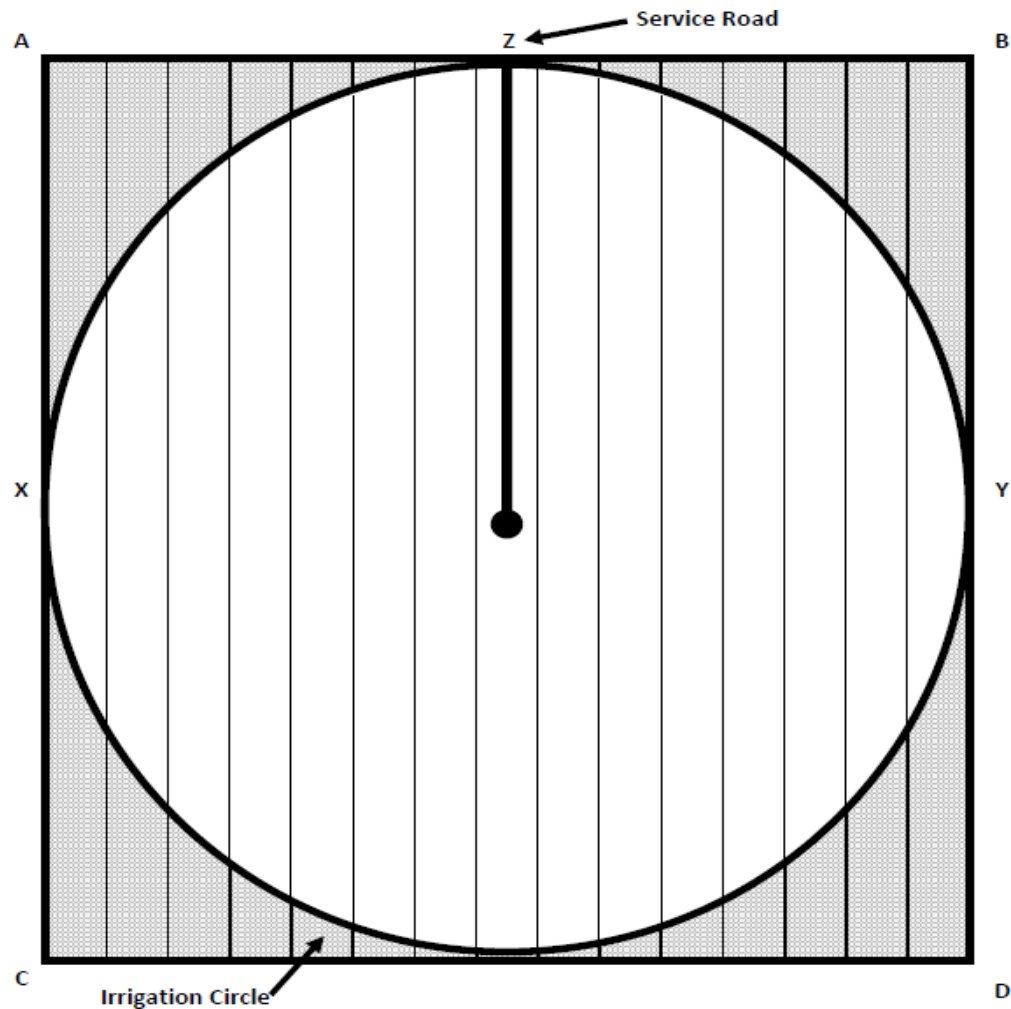

Scenario 2

The circle only, **not** including the shaded corners, is planted to corn for grain. In Nebraska and Kansas, the corners may be corn for grain but would not be considered since we differentiate between irrigated and non-irrigated plantings. Since the service road (point Z) is the most accessible corner in most cases, it would be considered the starting point. While standing at point Z, unit 1 will be laid out to the right (towards point X). After completing the Form B observations in Unit 1, start from the last pace required for Unit 1 and walk 30 paces parallel with the longer side of the field and in the same direction that you were traveling when you located Unit 1. Then turn at a right angle and walk 30 more paces into the field, to locate, lay out and mark Unit 2. If you have more than one sample to lay out in the field, the starting point for the second sample would be point X. The starting corner for a third sample would be point W and a fourth sample would start at point Y.

### Spiral or Circular Fields

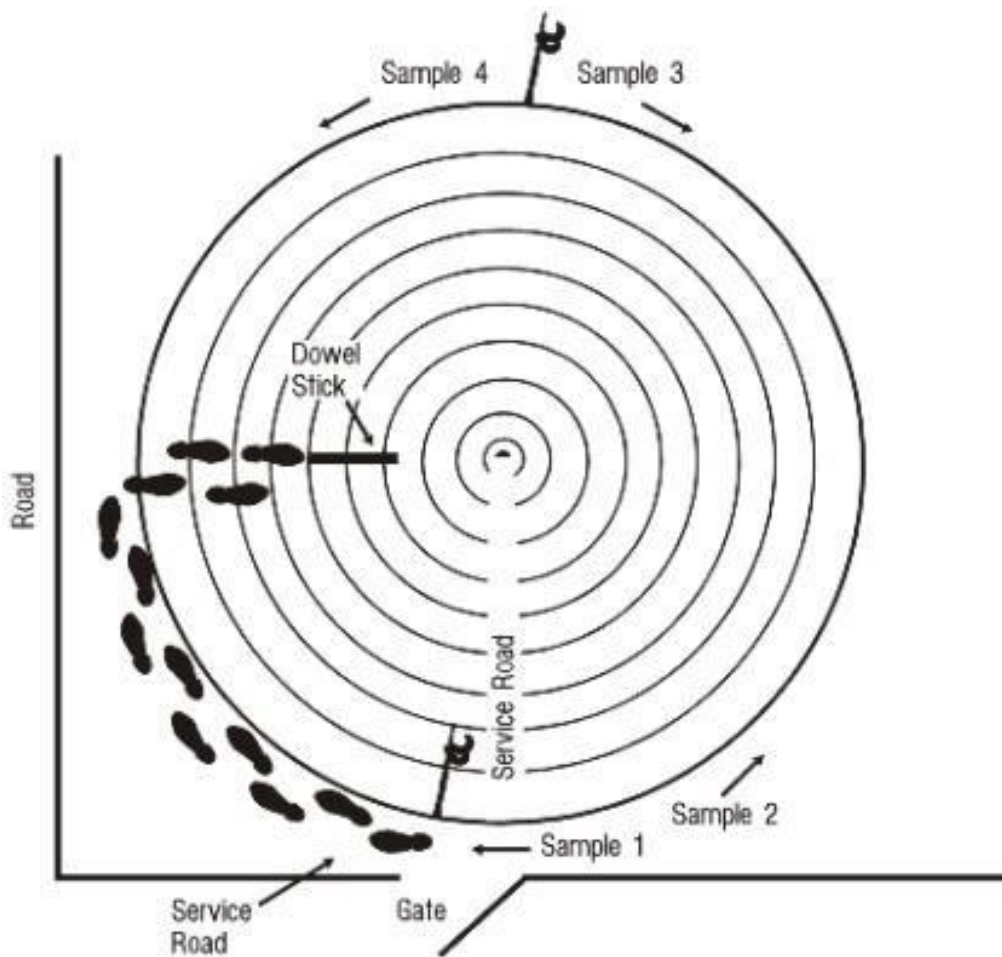

The starting point will be that point first reached when arriving at the field. To locate sample units in spiral or circular fields, use paces as shown on the Form B when walking along the edge of the field. Then use the number of rows shown on the Form B to count rows into the field. Be sure your diagram on the sample kit envelope is complete and is easy to follow in locating the sample units in the spiral or circular field.

A second sample in a circular field would be located in a counter-clockwise direction from the original starting point. If a third sample was selected, go to the opposite side of the field from the original starting point and locate the third sample in a clockwise direction and if a 4th sample, locate in a counter-clockwise direction.



## Chapter 5 – Form B

### General

The Form B counts and measurements are used to forecast production during the season and to set the end of season production estimate of corn for grain. Each item counted and measured is a very important part of this yield estimate.

Lay out all samples during the September 1 survey period. Unit 2 will be worked before Unit 1 during the November 1 survey periods because maturity is determined from ears beyond Unit 2. After the September 1 and October 1 survey period, work Unit 1 first.

Two units will be laid out for each sample on the first visit to the field. Since the same units will be used each month, proceed directly to the units by the most accessible route on successive monthly visits.

If the field counts cannot be made, complete a Form B in CAPI, with a comment explaining the reason the sample could not be laid out. The sample will be laid out the following month if the field is still standing for harvest. Every effort should be made to complete all B forms each month.

All notes concerning the field that may be useful to you or your supervisor should be recorded on the field kit envelope.

### Data Quality

You need to be careful when making the counts and measurements required by the Form B. This section contains examples showing how small differences in the counts and measurements you make can change a sample's gross yield forecast. The examples deal with counting the number of ears, the 4-row space measurement, and the diameter measurement.

**Example 1.** This example shows how changes in the number of ears with kernel formation can change the yield. In this example, we will first calculate the gross yield for a sample using 80 ears from the two units, then with 84 ears in the two units. This difference of 4 ears is a change of 5 percent. We will use 10.4 feet for the average 4 row space measurement and 0.300 lbs. per ear for the average ear weight in both cases.

The first step is to calculate the number of ears per acre. This is done by adjusting the number of ears in the two units to represent one acre. To do this, the number of ears in the two units is multiplied by the ratio of 43,560 square feet in an acre to the total square feet in both units. The total square feet in both units is calculated by multiplying the average of the 4 row measurements and the length of a unit, 15 feet. If there are 80 ears in the two units, then the ears per acre is calculated by:

$$80 \text{ ears} \times \frac{43,560 \text{ sq. ft. per acre}}{10.4 \text{ ft. per 4 rows} \times 15 \text{ ft.}} = 22,338 \text{ ears per acre.}$$

The next step is to multiply the number of ears per acre by the average grain weight and convert to bushels per acre:

$$22,338 \text{ ears per acre} \times \frac{0.300 \text{ lbs. per ear}}{56 \text{ lbs. per bushel}} = 119.7 \text{ bushels per acre.}$$

Repeating the process for 84 ears in both units gives us:

$$84 \text{ ears} \times \frac{43,560 \text{ sq. ft. per acre}}{10.4 \text{ ft. per 4 rows} \times 15 \text{ ft.}} = 23,455 \text{ ears per acre}$$

and

$$23,455 \text{ ears per acre} \times \frac{0.300 \text{ lbs. per ear}}{56 \text{ lbs. per bushel}} = 125.7 \text{ bushels per acre.}$$

In this example, a 5 percent change in the number of ears changed the gross yield by 5 percent.

**Example 2.** This example shows how changes in the 4-row space measurement can change the gross yield. We will calculate the gross yields from units with average 4 row space measurements of 10.0 and 10.4 feet. This is a 4 percent difference. We will use 80 ears in the two units and 0.300 lbs. per ear for both examples.

The ears per acre is:

$$80 \text{ ears} \times \frac{43,560 \text{ sq. ft. per acre}}{10.0 \text{ ft. per 4 rows} \times 15 \text{ ft.}} = 23,232 \text{ ears per acre.}$$

If the forecasted ear weight is 0.300 lbs. per ear, the yield per acre is

$$23,232 \text{ ears per acre} \times \frac{0.300 \text{ lbs. per ear}}{56 \text{ lbs. per bushel}} = 124.5 \text{ bu. per acre.}$$

If the 4 row space measurement is 10.4 feet, then the ears per acre is

$$80 \text{ ears} \times \frac{43,560 \text{ sq. ft. per acre}}{10.4 \text{ ft. per 4 rows} \times 15 \text{ feet per unit}} = 22,338 \text{ ears per acre ,}$$

and the yield per acre is

$$22,338 \text{ ears per acre} \times \frac{0.300 \text{ lbs. per ear}}{56 \text{ lbs. per bushel}} = 119.7 \text{ bu. per acre.}$$

Again, a 4 percent change in the average 4 row space changes the gross yield by 4 percent.

**Example 3.** This example shows how changes in the diameter measurement could change a sample's gross yield. We use the ear diameter and kernel row length measurements of the 5 ears beyond the unit to estimate the average volume.

A regression model is used to convert this volume measurement to an average weight per ear. The following equation is an example of a regression model:

$$0.16407 + 0.00967 \times (\text{average volume}) = \text{lbs. per ear.}$$

The numbers 0.16407 and 0.00967 are called coefficients. These coefficients vary by state, month, and maturity. Nebraska's and Kansas' coefficients also differ for irrigated and non-irrigated samples. HQ calculates the coefficients using the previous 5 years data.

If the 5 ears have an average volume of 16.0 cubic inches, we would forecast the ear weight to be:

$$0.16407 + 0.00967 \times (16.0) = 0.31879 \text{ lbs. per ear.}$$

If the number of ears in the unit converts to 23,000 ears per acre then the forecasted yield per acre for the unit would be:

$$0.31879 \text{ lbs. per ear} \times \frac{23,000 \text{ ears per acre}}{56 \text{ lbs. per bushel}} = 130.9 \text{ bushels per acre.}$$

Increasing each ear's diameter measurement by 1 mm could change the average volume to 17.1 cubic inches, then the average ear weight would be

$$0.16407 + 0.00967 \times (17.1) = 0.32943 \text{ lbs. per ear}$$

and the yield per acre would be

$$0.32943 \text{ lbs. per ear} \times \frac{23,000 \text{ ears per acre}}{56 \text{ lbs. per bushel}} = 135.3 \text{ bushels per acre.}$$

In this example, a 1 mm increase in the diameter measurement increased the gross yield forecast by just over 3 percent.

### Sample Identification

An ID label with the State code, POID and sample number has been pre-printed on the Form B. If this label is missing or illegible, copy the POID and sample numbers from the field kit envelope.



After verifying the label information enter the date in the space provided at the top of the Form B.

### Unit Location

Follow the instructions in Chapter 4 for locating the sample units.

#### UNIT LOCATION

1. Number of rows along edge of field.....
2. Number of paces into field.....

UNIT 1	UNIT 2
+ 30	
+ 30	

4. UNIT LOCATION CODE.....
  - 1 First visit to lay out unit
  - 2 Unit relocated this month
  - 3 Sample unit laid out previously

UNIT 1	UNIT 2
302	307

Enter Code

If code = 3, skip to Item 6

During the first visit to lay out the unit, enter a code "1" in the appropriate cell box and make row space measurements. If, during a later visit the unit cannot be located, enter a code "2" layout a new unit(s), and make row space measurements. During later visits to the same unit, enter a code "3" and skip the row space measurements.

### Pesticide Safety

Form B has a question just beneath the identification box asking if the operator has applied pesticides with organophosphorus content to the sample field. This will require contact with the farm operator or some other knowledgeable person. This question must be checked **YES** or **NO** for each Form B. If **YES** is checked the date of latest application and name of pesticide must be entered in the space provided.

3. Has operator applied pesticides with organophosphorus content to the sample field?

- YES                       NO

If YES, enter latest application date \_\_\_\_\_ and name of pesticide \_\_\_\_\_.

Exercise extreme caution to avoid exposure to dangerous pesticides. **Never enter a field if a pesticide has been applied earlier in the day.** Observe precautions described in Chapter 1.

**Row Space Measurement**

Row space measurements and ear counts are used to compute ears per acre. This is one of the components required to estimate yield.

5. **ROW SPACE MEASUREMENTS**

	UNIT 1	UNIT 2
a. Measure distance from stalks in Row 1 to stalks in Row 2 . Feet & Tenths	303 _____	304 _____
b. Measure distance from stalks in Row 1 to stalks in Row 5 . Feet & Tenths	305 _____	306 _____

At the dowel stick, measure the distance across the first row space with the steel tape. Anchor at the center of the stalks in row 1 and measure to the center of the stalks in row 2. This is the distance across the first middle. Record this distance in feet and tenths of feet in item 5a.

Measure the distance across 4 corn row spaces (5 adjacent rows) and record in item 5b. Measure at the dowel stick from the center of the stalks in row 1 (or twin row) to the center of the stalks in row 5. All measurements will be made in feet and tenths of feet.

Single Row Planted Row Space Measurements

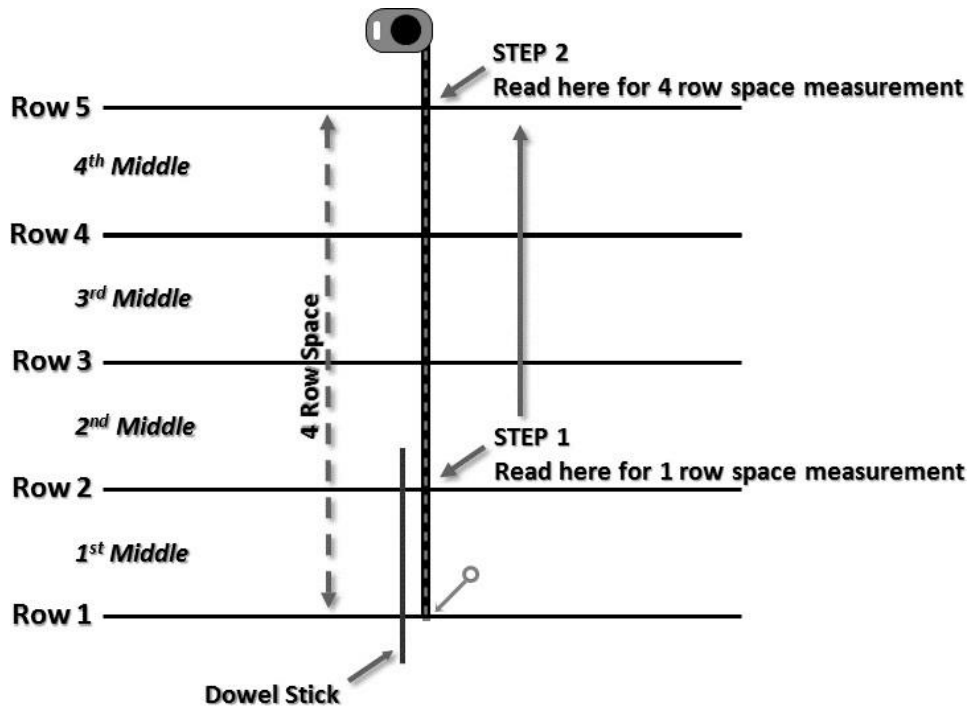

If the field is "skip planted" so that there are several rows of corn and then several rows of a second crop, record the planting pattern in the margin. For example, if the planting pattern is 2 rows corn, then 2 rows soybeans, the measurement recorded in item 5b is the sum of the distance between two rows of corn in four different strips. Apply the same principle if corn is planted in strips of three or four rows.

### Twin Row Planted Row Space Measurement

If a field is planted in twin rows, i.e., two pairs of narrow rows separated by a wide middle, (Example: a 7-inch middle followed by a 30-inch middle), the one-row space measurement recorded in Item 5a is the distance between the center of twin row 1 and center of twin row 2. The entry in Item 5b is the measurement from the center of twin row 1 to the center of twin row 5.

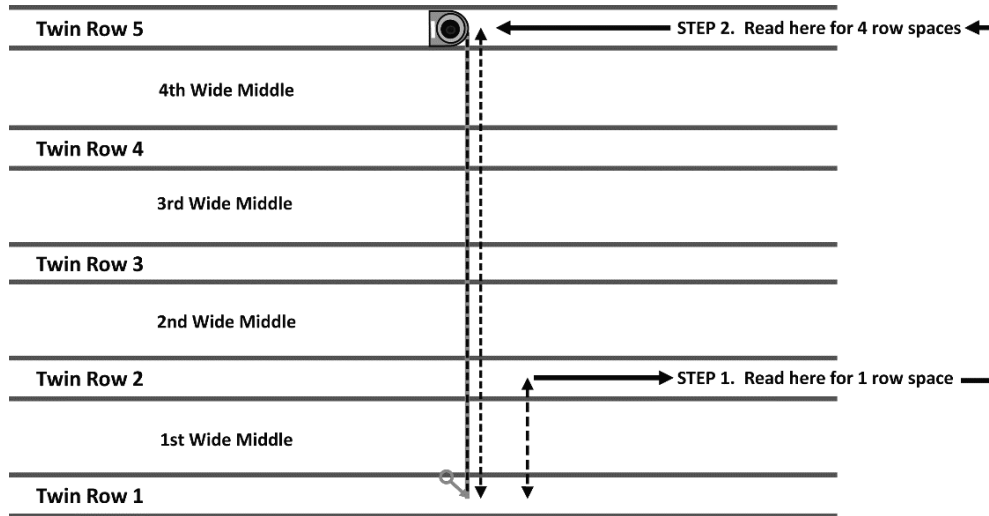

In all cases of unusual row spacing (very narrow, very wide, or non-uniform row space arrangement), or when the unit falls in a blank area of the field and no row space measurement can be made, write an explanatory note in the margin of the form.



## Maturity

The observations made beyond the unit provide the maturity stage of the sample. The maturity stage determines which forecast models will be used to forecast the number of ears, grain weight per ear and when a sample is mature.

The maturity determinations are made from 5 ears beyond a designated unit on a specific row each month. The stage of maturity determines which counts and measurements will be made. The table below shows where the observations are made each month:

### Designated Measurement Areas:

MATURITY CODES FOR ITEM 6			
For Month	Use Area Beyond	Maturity Code	
Sept. 1	Unit 1, Row 1	2 = Pre-Blister	5 = Dough
Oct. 1	Unit 1, Row 2	3 = Blister	6 = Dent
Nov. 1	Unit 2, Row 1	4 = Milk	7 = Mature

The maturity classification for each ear is based on distinct ear and plant characteristics. This is especially true in the case where the ear shoot develops a hard cob but no kernels. In this case, you must determine the maturity using other parts of the plant such as the silks and husks.

Use the descriptive material below as criteria for determining the maturity stage of each unit. The stage of maturity for each unit must be determined separately. There will be cases when you are undecided on the maturity stage of the unit. When this occurs, classify the unit in the lower stage of maturity.

## Corn Maturity Codes

### Maturity Code 2 - Pre-blister

Shoot has some silks showing. Little or no watery, clear liquid present in "spikelets."

### Maturity Code 3 – Blister

Most "spikelets" contain liquid. Most silks protruding from husks are beginning to turn color.

### Maturity Code 4 – Milk

Plant or shuck is green. Ears are erect. Little or no denting. Most kernels are full of milk-like substance, but kernels not fully grown. Silks protruding from husks have turned brown and dry.

### Maturity Code 5 – Dough

About one-half of kernels showing dent with some milk or dough-like substance in all kernels. Kernels full grown. Maturity line has not moved halfway to the cob on majority of kernels. Shucks taking on a light rust-colored appearance. Ears beginning to lean away from stalks.

### Maturity Code 6 – Dent

Ears are firm and solid. Kernels fully dented with no milk present in most kernels. Shucks are about dry but not beginning to open up. Kernels may be hard to scratch at surface, but still soft near the cob. Maturity line on the kernels has not reached the cob.

To differentiate between Code 6-Dent and Code 7-Mature ears, break the ears, observe the maturity line of the exposed kernels on the top half of the ear and test for milk on top of kernels next to the cob. To be in Code 7, the

maturity line of the exposed kernels on the top half must be down to the cob. This indicates that the corn is mature and reasonably represents actual harvest conditions. If there is doubt whether the maturity line has reached the cob, test for milk in the top part of the kernels next to the cob with your thumbnail.

**Maturity Code 7 – Mature**

Corn is about ready or ready for harvest. The maturity line on the kernels extends inward to the cob. No milk can be squeezed from the top of the kernels next to the cob when punctured with a thumbnail. Kernels shell off the cob fairly easily. When you pick a kernel from the cob, there may be a dark spot on the cob where the kernel was attached. Shucks are dry and are beginning to open up. No green foliage is present.

6. MATURITY CODE of first 5 ears or silked ear shoots

EAR NUMBER					TOTAL OF 5 EARS
1	2	3	4	5	
					301

Husk and inspect the first 5 ears or silked ear shoots in the designated measurement area for the stage of maturity.

If there is more than one ear on a stalk, follow the "TO BE" rule: TOP--ODD; BOTTOM --EVEN. Always count the top ear first for odd-numbered samples and the bottom ear first for even-numbered samples. Pull back the husks without removing the ears from the stalks and classify each ear as to stage of maturity. Enter the proper maturity code for each ear.

If the unit is at the edge of the field, go to the end of the next row - in the direction of travel (when counting rows) to find the five ears needed for maturity determinations and measurements.

If ears or silked ear shoots are not yet present in the unit or beyond the unit, check the appropriate space in the instruction above Item 6; then complete Item 11 only.

The remaining counts and measurements are based on the Item 6 maturity stages.

a. Will harvest occur within 3 days?

- No - Go to Item 6b
- Yes - Complete Items 11, 14, 15, 16 & 17

b. Are three or more ears in maturity code 7?

- No - Go to Item 6c
- Yes - Complete Items 11, 14, 15, 16 & 17

c. Does Item 301 equal 23 or more?

- No - Go to Item 6d
- Yes - Complete Items 7, 8, 9, 10, 11 & 14

d. Does Item 301 equal 13 to 22?

- No - Complete Items 11, 12, 13 & 14
- Yes - Complete Items 7, 8, 9, 10, 11, 12, 13 & 14

If 3 or more ears are Code 7, or the operator will harvest the sample within 3 days, complete stalk counts (Item 11) and ears counts (Item 14) in the 15 foot units and harvest the ears in row 1 of each unit (Items 15-17).

If the total in Item 6 is 23 or more, transfer maturity codes to Item 7 as specified, and measure kernel row lengths and ear diameters (Items 8 and 9) beyond the unit. If 3 or more of the 5 ears listed in Item 7 are Code 6 or 7, harvest the ears as specified (Item 10) and send them to the lab. Then complete stalk counts (Item 11) and ear counts (Item 14) in the 15-foot units.

If the total in Item 6 is 13 to 22, transfer maturity codes to Item 7 as specified, and measure kernel row lengths and ear diameters (Items 8 and 9) beyond the unit, then complete all stalk and ear counts (Items 11-14) in the 15 foot units.

If the total in Item 6 is 12 or less, make no further observations beyond the unit. Complete all stalk and ear counts (Item 11-14) in the 15 foot units.

When Item 6 has 3 or more code 6 ears, and the operator had earlier informed you that he planned to harvest the sample field as high moisture corn, determine if he still plans to harvest the corn at a high moisture level. If the operator has not changed his plans, determine when he plans to harvest.

		EAR NUMBER				
		1	2	3	4	5
7. Maturity code of each of the first 5 ears Code 3 or higher (copy maturity from Item 6. Replace Code 2 ears with next code 3 or higher.)..... Code	320	321	322	323	324	

If the sum of the maturity codes for the 5 ears in Item 6 totals 13 or more, copy the maturity code for each ear classified as Code 3 or higher directly to Item 7. Whenever the total of the 5 ears is 13 or more and any Code 2 ears are listed in Item 6, select the next ear beyond ear number 5 in the designated measurement area which is maturity Code 3 or higher. List its maturity code in Item 7.

**Kernel Row and Diameter Measurements**

The kernel row and diameter measurements are used to forecast grain weight per ear. You may remove the ear from the stalk if doing so makes it easier to make these measurements. Before removing the ear, you must do the following:

1. Husk the ear.
2. Pick a kernel row that intersects an imaginary line that runs through the center of the stalk and the center of the ear.
3. Mark this row with a black marker about one inch away from the butt of the ear.
4. Remove the ear from stalk being careful to not knock off any kernels, especially if the ears will be sent to the lab.
5. Mark on the ear, the order of the ear, i.e., ear 1 through ear 5.
6. Make kernel row length and diameter measurements as described later in this manual. When making the diameter measurement, center the marked row in the jaws of the caliper.

The average length of kernel row will be measured for each of the Code 3 or higher ears listed in item 7. The average kernel row length is the part of the cob length covered by kernels or "blisters".

8. Average length of kernel rows (Item 7 ears) ..... Inches & Tenths	326	327	328	329	330
	. ____	. ____	. ____	. ____	.

Select a specific kernel row (or a point on a specific row) to measure the length of that row. Enter the measurement data to one decimal. The tape must be graduated in inches and tenths of inches.

If a part of the ear is rotten or damaged, do not consider it part of the total cob length occupied by kernels. In measuring the average length of the kernel rows on ears with missing or damaged grains, visualize the kernels present forming a continuous row from the butt towards the tip by being moved adjacent to each other on the cob.

At least one kernel must be present on the cob to be considered an ear. An ear with only one kernel present should have an average kernel row length of .1 inch.

In item 9, enter the diameter of the ear measured one inch from the butt of the cob. Record measurements to the nearest tenth millimeter.

9. <b>Diameter of the ear</b> one inch from the butt of the cob. ( <i>Item 7 ears</i> ) . . . Millimeters & Tenths	336	337	338	339	340
	. ____	. ____	. ____	. ____	. ____

The caliper must be calibrated. To calibrate the caliper, close the jaws of the caliper. Rotate the dial to read 0.

Use the caliper to measure the diameters of the ears. The same five ears used for kernel row measurements will be used for diameter measurements. Ear 1 in the kernel row measurement should be ear 1 in the diameter measurement.

The ear will be completely husked. The husk should not interfere with the caliper jaws. The measurement is taken one inch from the butt of the ear. When measuring the diameter with the ear on the stock position the caliper so the jaws are pointed toward the stalk at a 90 degree angle with the ear in the mouth of the caliper. Close the caliper jaws by rotating the thumbscrew until the jaws are snug against the kernels. Do not tighten so much that kernels are damaged. Read the measurement from the scale (0 to 130 mm) on the stationary ruler portion of the caliper opposite the left side of the dial. Then read the dial to add the millimeters and tenths of millimeters to the stationary ruler reading. Record the measurement to the nearest tenth millimeter in the space provided.

The following figure shows how to read the diameter measurement on the caliper.

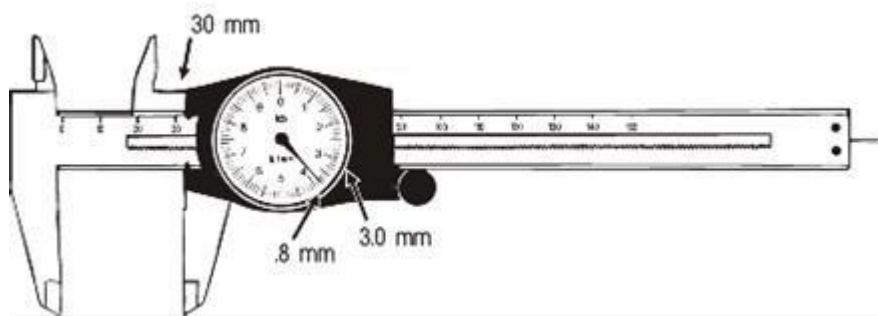

The numbers along the top part of the caliper are millimeters in groups of tens. The dial on the caliper gives the units place (the printed numbers) and the decimal place of tenths (the marks between the numbers). In the picture, the black pointer is on the 30 mm mark on the upper part of the caliper. The dial then gives the units place and the tenths decimal place. Here the pointer on the dial is on the 8 tenths mark, giving the reading of 3 units and 8 tenths, making the overall reading 33.8 mm.

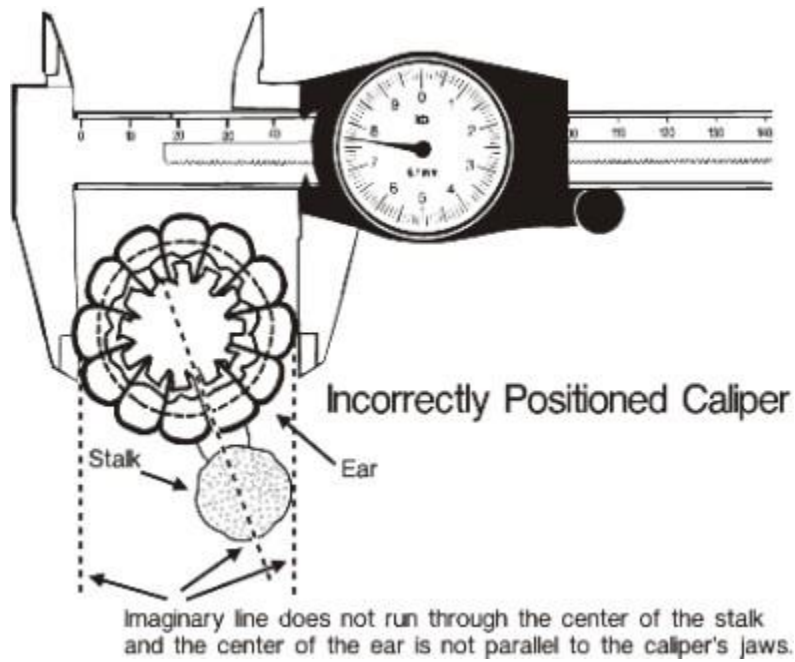
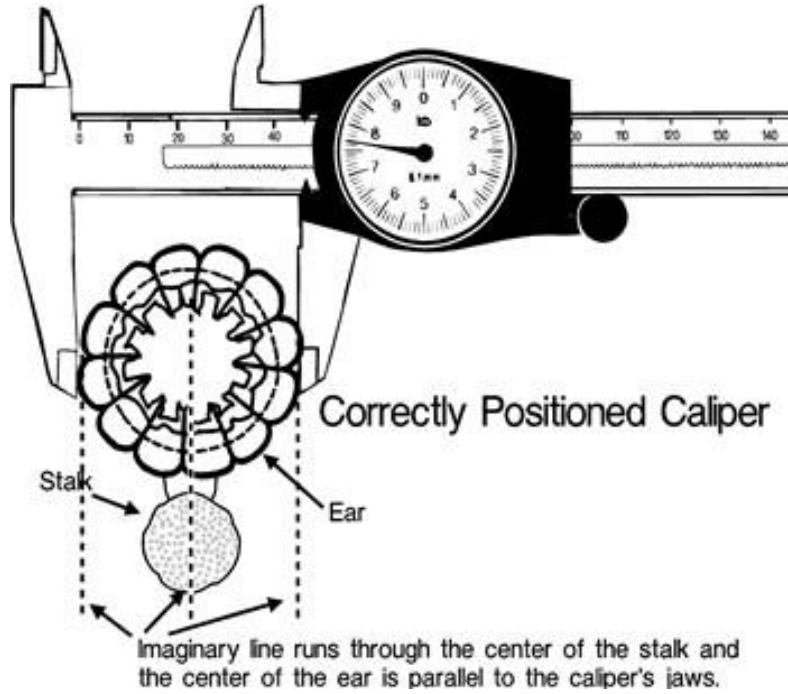

**Maturity Stage 6 Ear Weights**

10. Are 3 or more ears (*Item 7*) in maturity code 6 or 7?

No - Continue to Item 11

- Yes -
1. Harvest the first 5 ears beyond the unit which are coded 6 or 7.
  2. Place the third and fourth ears in a cloth bag and attach a completed ID tag to the outside.
  3. Place the other three (*first, second and fifth*) ears in a Tyvek envelope.
  4. Place the cloth bag containing the third and fourth ears in the envelope with the other three ears.
  5. Ship the sealed Tyvek envelope with all 5 ears to the National Lab.
  6. Check Here  when complete.

If three of the five ears used to determine the maturity are in maturity code 6 or 7 the sample will be used to calculate a maturity code six ear weight. We want to compare the code 6 ear weights with forecast model ear weights and the final ear weights.

The following outlines procedures for harvesting maturity stage 6 ears.

- Step 1:** Harvest the first 5 ears that are in maturity code 6 or 7, starting with the ears used to determine maturity. Continue harvesting ears, working away from the unit, until you have 5 ears in maturity code 6 or 7.
- Step 2:** Place the third and fourth ears in a cloth bag and attach a completed ID tag to the outside.
- Step 3:** Place the remaining three (first, second, and fifth) ears in a Tyvek envelope.
- Step 4:** Place the cloth bag containing the third and fourth ears in the Tyvek envelope with the other ears.
- Step 5:** Ship the sealed Tyvek with all 5 ears to the National Lab.

If any of the five ears were broken to determine maturity, put the broken ears and any loose kernels in the appropriate bag/envelope.

**Counts Within 15-Foot Units**

The counts made in the 15-foot units are used with the row space measurement to estimate ears per acre.

COUNTS WITHIN 15 FOOT UNITS	UNIT 1		UNIT 2	
	ROW 1	ROW 2	ROW 1	ROW 2
11. Number of stalks .....	331	332	333	334

For Item 11, count all stalks in each 15-foot row regardless of size or condition, even if damaged or removed from the unit. Do not count tillers (suckers) as stalks. Count the stalks at ground level. A tiller or sucker emerges from the ground close to the main stalk, often at a slight angle. Other features are the generally smaller size of the tiller compared with the main stalk, and usually (though not always) the lack of brace roots on the tiller. A main stalk and its tillers come from the same seed.

If you are uncertain whether a stalk is actually a tiller, go outside the unit and find a similar plant. Dig around the plant to determine whether it is a stalk or a tiller. If you determine it to be a tiller, tie a piece of flagging ribbon around the tiller and its main plant for reference in future months.

Any volunteer stalks growing in the row space between row 1 and row 2 are included in the count for row 1. Likewise, stalks between row 2 and row 3 will be included in the count for row 2.

Volunteer stalks growing in the row space between row 1 and row 2 or between row 2 and row 3 that are in clumps (several stalks originating from the ground in close proximity to each other) should be counted as only one stalk. Tie a piece of flagging ribbon around the entire clump for reference in future months.

Clumps in the rows will also be counted as one stalk and tied together with flagging ribbon.

Late in the growing season, mature seed may fall to the ground and germinate. Any plants which come from the current year's crop will be excluded from the plant count.

12. Number of stalks with ears or silked ear shoots (Item 12 cannot exceed Item 11 for any row.).....	341	342	343	344
--	-----	-----	-----	-----

Count the number of stalks in Item 12 that have ears or silked ear shoots on the main stalk, or if none on the main stalk, on a tiller from the main stalk. A silked ear shoot refers to the early formation of an ear on a stalk or tiller with some silk protruding beyond the husk. During the later stages of ear formation, if the silk dries up, and no evidence of kernel formation is present, do not include the ear shoot count in items 12 and 13. (A dried up silked ear shoot is not counted because it is NOT an ear). Item 12 for any row cannot be greater than Item 11, "total stalks".

13. Number of <b>ears</b> and silked ear shoots (Item 13 <i>MUST</i> equal or exceed Item 12 for any row.) . . . . .	351	352	353	354
---	-----	-----	-----	-----

The Item 13 count will include all ears and all ear shoots on which silks have emerged beyond the husks. Exclude dried up silked ear shoots with no evidence of kernel formation. In a few rare instances, more than one ear or ear shoot will protrude from a single node. A node is a fruiting position on the stalk. In these instances count each ear and/or shoot. Ears and silked ear shoots on tillers (or suckers) are also included in count. Kernel formation is evidence of silking.

14. Number of <b>ears</b> with evidence of <b>kernel formation</b> (Item 14 cannot exceed Item 13 for any row.) . . . . .	361	362	363	364
--	-----	-----	-----	-----

Item 14 is a count of all ears in which kernels have definitely begun to form. An ear of corn is defined as a cob having at least one kernel. Ears on tillers should be included in the count. To have evidence of kernel formation, ears must be in blister or later stages of maturity. Ears will have started to enlarge and will have a solid "feel" to them. Most silks protruding from the husks will be turning color or may be brown or dry.

The outline of the kernel rows may be felt through the husks, or kernels may be seen at the top of the cob.

In rare cases, more than one ear may develop at a node. If this happens, count each ear.

Do not remove or pull back the husks of ears in the unit to inspect for kernels. In doubtful cases, go outside the unit and inspect similar ears or ear shoots for the presence of kernels. Exclude any questionable ears from Item 14.

Ears with kernel formation found loose on the ground in row 1 and row 2 middles are included in the count of ears for their respective rows. Ears on the ground are also harvested during the final preharvest visit.

Deformities emerging as part of the tassel which resemble a small cob with some kernels are not considered ears and are not included in the count.

**Harvesting Sample Units**

When the sample is mature, row 1 of both units is harvested and weighed. The field weight helps establish the grain weight per ear. Also, the third and fourth ears are tagged and sent to the lab. These ears are used to determine the shelling fraction and moisture content.

The field weight of ears and lab data on grain weight and moisture content are used to estimate grain weight per ear.

If Item 6 indicated 3 or more Code 7 ears, the units are mature enough to harvest. After November 1: If the sample is not mature by the end of the November 1 survey period, keep in close contact with the operator and complete Form B prior to harvest or before the cut-off date. Your Survey Statistician will inform you of the cut-off date.

The third and fourth ears in row 1 of each unit, counting from the first stalk in the row, will be tagged with a rubber band. If there are less than four ears in a unit, the last ear and the next-to-last ear in the row are tagged with the rubber band.

**HARVESTING SAMPLE UNITS**

- 15. HUSK and TAG the 3rd and the 4th ears in Row 1 of both units. Husk remaining ears and weigh ALL ears with grain in Row 1 of each unit regardless of maturity stage.  
**Number of ears husked with grain (include 3rd and 4th ears).....**  
**Verify:** Cell 312 equals Item 14 cell 361 and cell 313 equals Item 14 cell 363

	UNIT 1, ROW 1	UNIT 2, ROW 1
Number	312	313

Unit 1 ears tagged with rubber bands must be bound together so they can be distinguished from the two ears in Unit 2.

In case there is more than one ear on a stalk, count the top ear first for odd numbered samples. For even numbered samples count the bottom ear first.

**Remember:** "TO BE" TOP--ODD; BOTTOM--EVEN.

An ear of corn is defined as a cob having at least one kernel. Husk each ear as cleanly as possible and deposit the ears in a bucket, sack or other container. Include any kernels that are shelled accidentally. Snap the shank off cleanly.

Count all ears husked from row 1 of each unit. Include the tagged ears in the count. Record the count in Item 15. The count of ears husked must equal the count with evidence of kernel formation recorded in item 14.



16. Weight of ears with grain and any accidentally shelled kernels from Row 1 of each unit (include 3rd and 4th ears, exclude weight of containers).....

Pound & Hundredths

314	315
. ____	. ____

After the ears have been picked and counted from row 1 of each unit, take the corn back to your car for weighing. Weigh all husked ears from row 1 of each unit separately and record in Item 16. Include third and fourth ears tagged with rubber bands in the weighing.

Balance the scales and adjust for the weight of the container before weighing. Use a tripod or other support for holding the scales steady. Do not attempt to hold the scales by hand. The scale reading should be verified by a second reading. Be accurate. Each 1/10 pound of corn at 30 percent moisture obtained from plots with 30-inch rows represents about 1/2 bushel in yield per acre.

Extra care should be taken when reading the scale when a large number of ears are weighed and the scale rotates past the 0.0 lbs. mark. Example, when 30 ears are weighed from unit 1 and the hand of the scale rotates past 0.0 to 5.3 lbs. the weight should be recorded as 15.3 lbs. (10.0 + 5.3). If the weight was recorded as 5.3, the yield for the field would be cut by approximately two thirds.

After weighing, put the third and fourth ears from row 1 of each unit in separate poly bags. Twist the neck of each bag several times to make it airtight and seal the bag with a rubber band. Complete and attach the sample ID tag with another rubber band. Place poly bags from Units 1 and 2 in a Tyvek envelope and ship to the National Lab".

**Do not place the ID tag inside the poly bag.**

### Special Problems

When returning to samples for the second or later monthly visits, you will generally have no problems finding the units and completing the form. However, for a few samples you may have problems. Handle these problems with the procedures indicated below.

**Problem 1: The crop is still standing, but you cannot find a unit.**

**Solution:** Lay out a new sample unit using the same number of rows along edge and paces into the field as shown on the Form B and kit envelope. Start from the same corner of the field as when the sample units were originally laid out. Enter a "2" in Item 4 for unit relocated and obtain row space measurements for the unit.

**Problem 2: Part of field has been destroyed before harvest, including the area where one or both sample units were located.**

**Solution:** Record dashes for each unit that was destroyed. Write "Unit \_\_\_\_\_ Destroyed" in the margin of Form B. If only one unit was destroyed, complete all items for the remaining unit. Do not count any paces when crossing the part of the field that was destroyed when locating post-harvest sample units.

**Problem 3: The entire field has been harvested for grain.**

**Solution:** Write "Field harvested" on Form B. Complete Form E if the field was selected for Post-harvest gleaning.

**Problem 4: Part of the field containing one unit has been cut for silage or harvested for grain and the other unit is still standing for harvest.**

**Solution:** Complete the appropriate Form B for the unit still standing for harvest and write notes explaining what happened.

**Problem 5: The sample field will be harvested before the next survey period, but the sample field is not quite mature.**

**Solution:** For this survey period, complete the Form B based on the current maturity. Keep in contact with the farmer and make a final preharvest visit just prior to harvest.

**Problem 6: The field was sprayed and could not be entered until near the end of the survey period.**

**Solution:** Complete the Form B when entry is allowed and telephone the data to the State office.

**Problem 7: The selected sample field is planted to seed corn. The operator reported that the selected field is planted to seed corn and only part of the field will be harvested for grain. The male rows have been or will be destroyed.**

**Solution:** On the Form A, do not deduct the acreage represented by the rows that have been or may be destroyed. Lay out the unit and measure row spaces the same as in any field. When determining row space measurements, count the row middles the same whether the male rows have been destroyed or not.

If one or both units may be destroyed after you lay out the unit, make notes for that row and make counts on the rows still standing.

**Problem 8: The unit(s) fell in a blank area and no plants are present.**

**Solution:** Write a note on the questionnaire explaining what happened. Complete the other unit if plants are present.

**Problem 9: Ears of corn infected with smut.**

**Solution:** Ears infected with smut are handled no differently than other ears. These ears are measured and weighed with smut intact. Do not clean ears of smut before sending to the lab.

**Problem 10: The unit to be used to determine maturity has been destroyed.**

**Solution:** Use the rows beyond the remaining unit.

After completing all observations, check the Form B for completeness. Sign your name and enter your enumerator number and supervisor number. If your supervisor assisted you or checked the unit, check the "YES" space. If no assistance was provided check the "NO" space. This question MUST be answered for each sample.

**Completing Corn Sample ID Tag**

**CORN SAMPLE I.D. TAG**  
-----  
(Circle Your State)

**IL IA IN KS MN MO NE OH SD WI**

POID \_\_\_\_\_

SAMPLE NO. \_\_\_\_\_

FORM B DATE: \_\_\_\_\_

FORM E DATE: \_\_\_\_\_

ENUMERATOR \_\_\_\_\_

-----  
**IF PRE-HARVEST (CODE 6)**  
**SAMPLE  CHECK**  
-----

**AT HARVEST SAMPLE**  
**UNIT 1  UNIT 2**   
-----

**POST-HARVEST GLEANINGS**

SHELLED GRAIN FROM EARS (    )

LOOSE GRAIN FROM GROUND (    )

-----  
**SHIP SAMPLE TO**  
**NATIONAL OPERATIONS DIVISION LAB**     

An ID tag must be completed and attached, using a rubber band, to the outside of each poly bag for each sample sent to the National Lab. These tags are essential in maintaining the identity of the samples from the time they leave the field until they reach the final step of the lab process. Do not put the ID card inside the poly bag with the sample. The ID tag absorbs moisture and cannot be read in the lab.

An example of the ID tag with instructions for completing the tag is shown below. A total of five ID tags per sample could be used.

**Identification**

All lines of the ID section must be completed for proper identification of the sample. The date should always match the date on the corresponding B or E Form.

### **Twin Row Sample Harvest**

The harvest procedures used for twin row planted fields are conducted using the same procedures used for the single row planted samples with the inclusion of the twin row.

#### **Preharvest**

For maturity code six samples check this section if sample contains the ears for the maturity code six ear weight.

#### **At Harvest**

If the sample is the at harvest sample, this section should be checked. Be sure proper unit is checked.

1 ID tag with Unit 1

1 ID tag with Unit 2

#### **Post-harvest**

If shelled grain, check the appropriate space and attach to the bag with grain shelled from ears.

If loose grain, check the space provided and attach to the bag with the loose grain gleaned from the ground in the row middles.

## FORM B CORN YIELD COUNTS - 2023

OMB No.: 0535-0088  
Approval Expires: 3/31/2024  
Project Code: 104  
Survey ID: 3224



Date: \_\_\_\_\_

**UNIT LOCATION**

		UNIT 1		UNIT 2
1. Number of rows along edge of field.....	+ 30			
2. Number of paces into field.....	+ 30			

3. Has operator applied pesticides with organophosphorus content to the sample field?  
 Yes                       No

If YES, enter latest application date \_\_\_\_\_ and name of pesticide \_\_\_\_\_

4. UNIT LOCATION CODE.....

		UNIT 1		UNIT 2
1 First visit to lay out unit		302		307
2 Unit relocated this month				
3 Sample unit laid out previously				

Enter Code

If code = 3, skip to Item 6

**5. ROW SPACE MEASUREMENTS**

		UNIT 1		UNIT 2
a. Measure distance from stalks in Row 1 to stalks in Row 2.....	Feet & Tenths	303	_____	304
b. Measure distance from stalks in Row 1 to stalks in Row 5.....	Feet & Tenths	305	_____	306

**Designated Measurement Areas:**

MATURITY CODES FOR ITEM 6			
For Month	Use Area Beyond	Maturity Code	
Sept. 1	Unit 1, Row 1	2 = Pre-Blister	5 = Dough
Oct. 1	Unit 1, Row 2	3 = Blister	6 = Dent
Nov. 1	Unit 2, Row 1	4 = Milk	7 = Mature

Husk the first 5 ears or silked ear shoots beyond the unit in the designated measurement area and examine for maturity. Enter the maturity code in the box for the corresponding ear, sum the five maturity codes and enter the total in cell 301.

If ears or silked ear shoots are not yet present, Check  and complete Item 11 only.

EAR NUMBER					TOTAL OF 5 EARS
1	2	3	4	5	
					301

**6. MATURITY CODE of first 5 ears or silked ear shoots**

<p>a. Will harvest occur within 3 days?</p> <p><input type="checkbox"/> No - Go to Item 6b</p> <p><input type="checkbox"/> Yes - Complete Items 11, 14, 15, 16 &amp; 17</p>	<p>b. Are three or more ears in maturity code 7?</p> <p><input type="checkbox"/> No - Go to Item 6c</p> <p><input type="checkbox"/> Yes - Complete Items 11, 14, 15, 16 &amp; 17</p>
<p>c. Does Item 301 equal 23 or more?</p> <p><input type="checkbox"/> No - Go to Item 6d</p> <p><input type="checkbox"/> Yes - Complete Items 7, 8, 9, 10, 11 &amp; 14</p>	<p>d. Does Item 301 equal 13 to 22?</p> <p><input type="checkbox"/> No - Complete Items 11, 12, 13 &amp; 14</p> <p><input type="checkbox"/> Yes - Complete Items 7, 8, 9, 10, 11, 12, 13 &amp; 14</p>

		EAR NUMBER				
		1	2	3	4	5
7. Maturity code of each of the first 5 ears Code 3 or higher (copy maturity from Item 6. Replace Code 2 ears with next code 3 or higher.).....	Code	320	321	322	323	324
8. Average length of kernel rows (Item 7 ears).....	Inches & Tenths	326	327	328	329	330
9. Diameter of the ear one inch from the butt of the cob (Item 7 ears).....	Millimeters & Tenths	336	337	338	339	340

10. Are 3 or more ears (Item 7) in maturity code 6 or 7?

No - Continue to Item 11

- Yes -
1. Harvest the first 5 ears beyond the unit which are coded 6 or 7.
  2. Place the third and fourth ears in a cloth bag and attach a completed ID tag to the outside.
  3. Place the other three (first, second and fifth) ears in a Tyvek envelope.
  4. Place the cloth bag containing the third and fourth ears in the envelope with the other three ears.
  5. Ship the sealed Tyvek envelope with all 5 ears to the National Lab.
  6. Check Here  when complete.

**COUNTS WITHIN 15 FOOT UNITS**

11. Number of stalks .....
12. Number of stalks with ears or silked ear shoots (Item 12 cannot exceed Item 11 for any row.).....
13. Number of ears and silked ear shoots (Item 13 MUST equal or exceed Item 12 for any row.).....
14. Number of ears with evidence of kernel formation (Item 14 cannot exceed Item 13 for any row.).....

		UNIT 1		UNIT 2	
		ROW 1	ROW 2	ROW 1	ROW 2
		331	332	333	334
		341	342	343	344
		351	352	353	354
		361	362	363	364

**HARVESTING SAMPLE UNITS**

15. HUSK and TAG the 3rd and the 4th ears in Row 1 of both units. Husk remaining ears and weigh ALL ears with grain in Row 1 of each unit regardless of maturity stage.

**Number of ears husked with grain (include 3rd and 4th ears).....** Number

**Verify:** Cell 312 equals Item 14 cell 361 and cell 313 equals Item 14 cell 363

UNIT 1, ROW 1	UNIT 2, ROW 1
312	313

16. Weight of ears with grain and any accidentally shelled kernels from Row 1 of each unit (include 3rd and 4th ears, exclude weight of containers).....

Pound & Hundredths

314	315
-----	-----

17. Place 3rd and 4th ears of Row 1 in separate plastic bags for each unit. After completing Items 15 and 16, send 3rd and 4th ears to the National Lab.

18. Did you leave the ears of corn where the operator requested?

Yes     No

ENUMERATOR COMMENTS: \_\_\_\_\_

ENUMERATOR: \_\_\_\_\_

19. Did a supervisor assist you in working a sample?     Yes     No

UPS Tracking Number: \_\_\_\_\_

(For samples sent to National Laboratory)

Enumerator Number	390
Supervisor Number	391
Evaluation	393

STATUS CODE 380

## Shipping Samples to the Objective Yield National Lab

### Good shipping procedures:

- Reduce transit time
- Reduce loss of samples whenever a shipping tag is destroyed in transit
- Improve sample quality received in the lab
- Do not interrupt lab workflow

### Shipping samples in the Tyvek Envelopes:



- Include both units if available and if both will fit into one Tyvek envelope. Include an ID tag with each unit. If only one unit is being shipped, include a second loose ID tag for the missing unit showing the reason for its absence (lost to harvest, not planted, drowned out, blank area, etc.)
- Regional Field Offices will be using the yellow 12" x 15.5" Tyvek envelopes will be used for shipping Corn Objective Yield samples to the National Lab.
- RFO's should place a shipping label on the Tyvek envelope and seal it for shipping to the NOD.



There are two procedures for shipping samples to the National Lab. Field enumerators should utilize UPS shipping when available.

**UPS 2<sup>nd</sup> Day Air or UPS Next Day Air Option**



- The samples should be taken to a UPS drop off location or a UPS store. If approved, you may also request a pickup by UPS.

**USPS Option**



- The samples should be taken to the front desk of a post office or sub-station that is still open, unless you have made previous arrangements with the post office where you drop the samples off. The post office may be apprehensive if they find the Tyvek envelope in an outside drop box without their prior knowledge.

### The Dos & Don'ts of Packaging and Shipping Corn Samples:

- Do:** Make notes on the Sample ID Tags such as “Unit 1 harvested by farmer before sample could be taken” are helpful.
- Do:** Use paper bags for post-harvest gleanings and enclose with the Form E in the Tyvek envelope. If the gleaned grain is very wet, you may need to use Tyvek envelopes instead of paper bags to eliminate the possible problem of paper bags bursting inside the Tyvek envelope. If this is the case, use one Tyvek envelope for the loose grain and another for the shelled grain from ears (corn), placing both inside the Tyvek shipping envelope.
- Do:** Completely fill out the ID tag, making sure that the date and POID on the ID tag matches the date and POID on the Form B or Form E. The lab will use the date on the ID tags for the lab forms.
- Do:** Place ID tag on the outside of paper bag. Secure bag with rubber bands.
- Do:** Ship only one sample (2-units) per Tyvek shipping envelope. When paper bags are broken during shipping, there are enough problems to contend with when only one sample is involved in the Tyvek envelope. Shipping only one sample per Tyvek envelope helps control the potential of combining of samples. If the samples are combined they are unable to be processed at the National Lab and the lost samples will not have the respective needed to assess a final yield for the sample(s).
- Do:** Ship Form B to the office in a separate envelope. Send forms for refusals or “no gleanings” to the office, not to the lab.
- Do:** Ship samples as soon as possible (within 24 hours) after they have been taken from the field. Do **not** hold them more than one day.
  
- Don't:** Use red pencil or pen on ID tags.
- Don't:** Staple ID tags to paper or plastic bags (corn).
- Don't:** Use poly bags for post-harvest gleanings unless sample is too wet to be contained by a paper bag.
- Don't:** Use tape of any kind on paper bags containing field samples. This creates a major inconvenience at the national laboratory and interrupts the sample processing work flow.

## Chapter 6 – Form E

### General

The Form E is used to collect information to determine the harvest loss so net yield can be calculated. Every fourth sample has been selected for gleaning. Because of the small sample size it is important to complete Form E for every assigned field or alternate field when possible. Complete the Form E for the assigned field even if it was harvested before the final Form B could be completed.

If the sample field has been disked, plowed or grazed, an alternate field will be selected if possible. If there is more than one field in the tract harvested for grain, select the field closest to the sample field as the alternate. If there are no other fields harvested for grain or all other fields have been disked, plowed or grazed, no alternate can be selected.

If harvest in that portion of the sample field containing one or both preharvest units is not complete, Post-harvest observations can be made in the harvested portion of the sample field. If another part of the sample field is used, start the count of rows and paces in the harvested area nearest the starting corner. Use the bounce back technique if necessary.

### Form E

#### UNIT LOCATION

1. Number of rows along edge of field.....
2. Number of paces into field.....

UNIT 1	UNIT 2
<b>+ 5</b>	<b>+ 5</b>
<b>+ 5</b>	<b>+ 5</b>

The Form E units are located using the same number of paces as used for Form B units, plus five

#### FIELD OBSERVATIONS

3. Measure distance from stalks in Row 1 to stalks in Row 2..... Feet and Tenths
4. Measure distance from stalks in Row 1 to stalks in Row 5..... Feet and Tenths

UNIT 1	UNIT 2
701 ..... .....	702 ..... .....
703 ..... .....	704 ..... .....

At the dowel stick, measure the distance across the first row space beginning at the center of the stalks in the Row 1 and measuring to the center of the stalks in Row 2. Next, measure the distance across four row spaces. Start at the dowel stick from the center of the stalks in row 1 and measure in the direction of row 2 across four row spaces to the center of the stalks in row 5. Record distances in feet and tenths of feet. If skip planted, follow instructions shown in Chapter 5.

5. Pick up all ears attached to stalks, all ears, and pieces of ears with kernels in each row middle. Shell and deposit all grain in paper bag. Identify bag as "shelled grain" . . . . .

	ROW 1	ROW 2	ROW 1	ROW 2
Check	<input type="checkbox"/>	<input type="checkbox"/>	<input type="checkbox"/>	<input type="checkbox"/>

Pick up all ears attached to stalks in rows 1 and 2 of the 15-foot section and all ears and pieces of ears, Large or small, lying on the ground inside the unit. The unit includes the area from the row 1 stalks up to, but not including, the stalks in row 3.

When uncertain whether ears should be included or excluded refer to the illustration on page 603.

When facing a gleanings sample, the horizontal line immediately in front at the 5 foot markers, and the side to your left will be the INCLUDE SIDES. The side opposite from you and the right side will be the EXCLUDE SIDES. All ears, including those partially in and partially out, will be EXCLUDED from the count and weight from the EXCLUDE sides. Those partially in and partially out will be INCLUDED from the INCLUDE SIDES.

Exercise extreme care in gleaning the unit. One average size ear of corn inside the unit represents a 3 bushel harvest loss. Shell and deposit all grain in a paper bag. This bag will be used for both Units 1 and 2. Identify this bag as "shelled grain". If the grain is wet and the paper bag will not hold the grain, put the grain in a poly bag.

6. Pick up loose grain in the middle of first row of each unit. Deposit in separate paper bag. Identify bag as "loose grain" . . . . .

Check	<input type="checkbox"/>	<input type="checkbox"/>
-------	--------------------------	--------------------------

From row 1 and its associated middle, up to, but not including row 2, pick up all loose grain on the ground in each unit and deposit in a different paper bag from that used for the Item 5 grain. Identify as "loose grain". The same bag will be used for both units. Clear away all trash to expose any grains that may be hidden. A combine or tractor wheel may run over an ear of corn and crush it or press it into the ground. When this happens only the grain still attached to the cob should be deposited in the bag as "shelled grain". The remainder of the grains gleaned is "loose grain".

Pieces of ears that were overlooked in Item 5 and are found during the gleaning for loose grain should be shelled and included with the loose grain. **Do not include these pieces with the item 5 grain.**

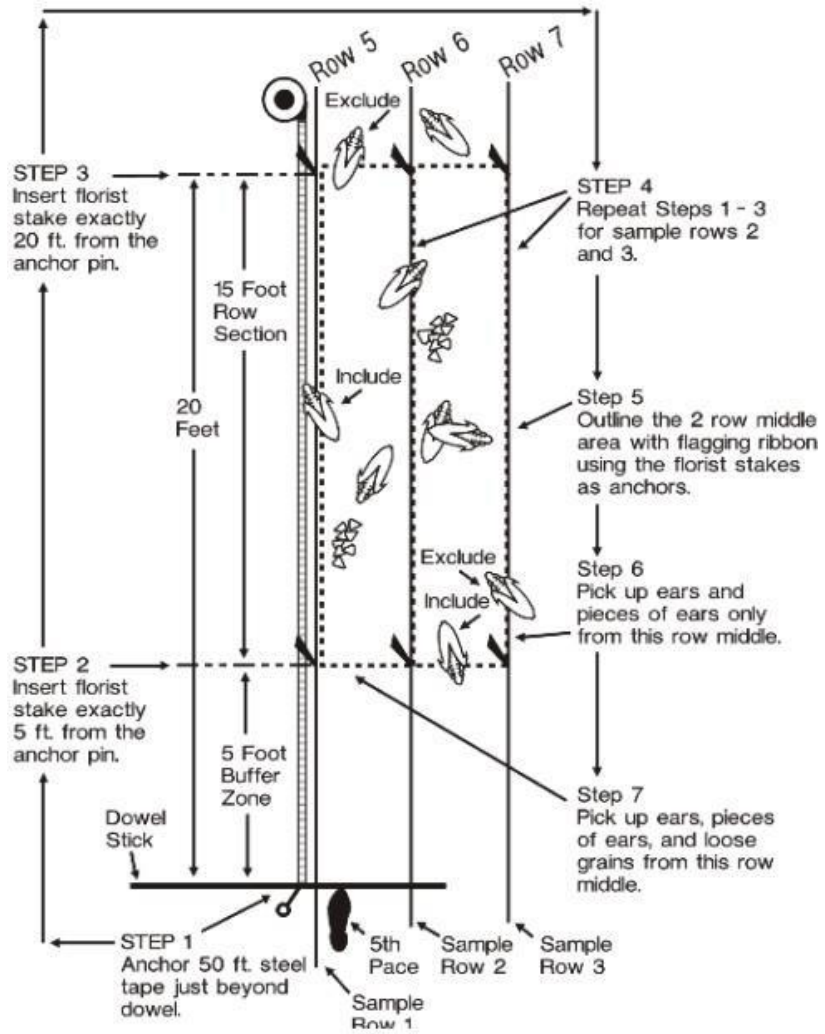

7. Was an alternate field used for making post-harvest observations?

- Yes - (Indicate in Field Notes)       No

**FIELD NOTES:** If post-harvest observations cannot be made, give reasons

---

---

Check "YES" or "NO". If it was not possible to make the Post-harvest observations, explain fully in field notes.

8. Did a supervisor assist you in working this sample?       Yes       No

<b>SHIPPING INSTRUCTIONS:</b> <ul style="list-style-type: none"><li>• Attach completed ID tag to the paper bag(s) containing gleanings.</li><li>• Place bag(s) and this Form E in a Tyvek envelope.</li><li>• Ship Tyvek envelope to National Lab.</li><li>• Record The UPS Tracking Number on the Kit Envelope</li></ul>
---

Enumerator Number	790
Supervisor Number	791

ENUMERATOR: \_\_\_\_\_

<b>STATUS CODE</b>	780
--------------------	-----

Ship the Form E to the State Office if observations could not be made.

Enter your enumerator and supervisor number, and sign your name.

THE BACK OF THE FORM E IS FOR OFFICE USE ONLY.

**Shipping Samples**

After the gleaning work is completed in both units, attach ID tag to the paper bag(s) containing gleanings. Place bag(s) and Form E in a Tyvek envelope and ship to the National Lab.

Record The UPS Tracking Number on the Kit Envelope.

**FORM E CORN OBJECTIVE YIELD - 2024**

OMB No.: 0535-0088  
Approval Expires: 7/31/2026  
Project Code: 104  
Survey ID: 3227



Please make corrections to name, address and ZIP Code, if necessary. Date: \_\_\_\_\_

**NOTE:**The post-harvest field gleanings should be completed as soon after harvest as possible, and must be done within 3 days after harvest. If the sample field has been plowed, disked, or pastured since harvest, select an alternate field for gleaning if one is available in the tract.

**UNIT LOCATION**

	UNIT 1	UNIT 2
1. Number of rows along edge of field.....	+ 5	+ 5
2. Number of paces into field.....	+ 5	+ 5

**FIELD OBSERVATIONS**

	UNIT 1	UNIT 2
3. Measure distance from stalks in Row 1 to stalks in Row 2..... Feet and Tenths	701 - ____	702 - ____
4. Measure distance from stalks in Row 1 to stalks in Row 5..... Feet and Tenths	703 - ____	704 - ____

**GLEANINGS IN 15-FOOT UNITS**

CHECK EACH BOX AS COMPLETED

	ROW 1	ROW 2	ROW 1	ROW 2
5. Pick up all ears attached to stalks, all ears, and pieces of ears with kernels in each row middle. Shell and deposit all grain in paper bag. Identify bag as "shelled grain"..... Check	<input type="checkbox"/>	<input type="checkbox"/>	<input type="checkbox"/>	<input type="checkbox"/>
6. Pick up loose grain in the middle of the first row of each unit. Deposit in separate paper bag. Identify bag as "loose grain"..... Check	<input type="checkbox"/>		<input type="checkbox"/>	

7. Was an alternate field used for making post-harvest observations?  
 Yes - (Indicate in Field Notes)       No

**FIELD NOTES:** If post-harvest observations cannot be made, give reasons  
 \_\_\_\_\_  
 \_\_\_\_\_

FORM E: CORN - continued

8. Did a supervisor assist you in working this sample?  Yes  No

**SHIPPING INSTRUCTIONS:**

- a. Attach completed ID tag to the paper bag(s) containing gleanings.
- b. Place bag(s) and this Form E in a Tyvek envelope.
- c. Ship Tyvek envelope to National Lab.

Enumerator Number	790
Supervisor Number	791

ENUMERATOR: \_\_\_\_\_

STATUS CODE	780
-------------	-----

**NATIONAL LABORATORY DETERMINATIONS**

Date sample received in lab (MM DD) \_\_\_\_\_

9. Weight of grain from ears.....	Grams to Hundredths	707
10. Weight of loose grain from ground.....	Grams to Hundredths	708
11. Moisture %.....	Percent (One Decimal)	709

*<sup>1</sup>If sample weight is too small for moisture test, sufficient grains of known moisture content will be added to the sample so that a moisture test can be made. The moisture content of the sample can then be derived using the following formula:*

$$E = \frac{(A + B) D - (B \times C)}{A}$$

Where A = Weight of small corn sample (item 7 & 8) .....	_____	Grams
B = Weight of additional grains required for moisture test .....	_____	Grams
C = Moisture percent of B .....	_____	Percent
D = Moisture percent of A + B combined .....	_____	Percent
E = Result: Moisture percent of small sample (enter in item 9) .....	_____	Percent

Lab Technician(s) \_\_\_\_\_

Date Analysis Completed \_\_\_\_\_  
MM DD



## Chapter 7 – CAPI Data Entry

### General

CAPI will be used for data entry for Forms A and B records. All data will be recorded on the paper forms during the interview with the operator and in the field. After the field visit is complete the enumerator will access their assignment listing on the iPad and enter the data for their samples into the CAPI forms exactly as it was recorded on the paper forms in the field and submit the record after data entry has been completed.

**\*\*\*IMPORTANT: NEVER take the iPad into a field under any circumstance.\*\*\***

Enumerators may decide to enter the data immediately after they have exited the field or at the end of the day after all of their work has been completed. To take full advantage of the mobile data collection technology developed for this survey it is highly recommended for all data to be entered and submitted by the end of the day it was collected. RFO survey coordinators will provide specific instructions on how they wish to handle the completed paper forms for samples entered and submitted via CAPI.

### Survey Designer and Edit System

CAPI instruments are designed in a system called Survey Designer. In this system the user has the ability to develop certain edits, which can assist the enumerator in making sure certain required cells are complete before final submission of the form through CAPI. These edits are a system of background checks within the CAPI instrument which will notify users of specific corrective actions that must be taken before proceeding with data entry. There are also certain data item checks that can be programmed in to assure completeness of the form. These depend on the OY survey being done and the crop.

These edits will help users submit complete records that meet the basic requirements of the survey edit system used for processing OY Survey data at the Regional Field Offices.

#### Examples of Edits in Place:

- Fieldwork Date must be set before entering any other data in the form.
- A Status Code must be selected before proceeding to the next page.
- When Unit Location = 3- Unit Laid out Previously, the row space measurement cells are hidden. This is in place because the row space measurement does not change in a sample unit from month to month without first relocating it to a new position in the sample field.
- When Unit Location = 1 or 2, Row space measurement is required before proceeding.
- Enumerator and Supervisor fields must be complete before proceeding.

**NOTE:** Edits will not correct errors in entering the data. It is imperative that the user key the correct data in from the paper form, and into the correct cells in CAPI.

Always review your work before data entry and final submission. Errors on the paper form will also be errors when they are loaded to the survey edit system.

## CAPI Form A and B Status Codes

Prior to the implementation of CAPI data collection in the Objective Yield Survey status codes were determined by the survey statistician based on the data reported by the enumerator who completed the form.

The status code is used to identify the sample unit's status for the current enumeration period based upon recorded observations.

A status code must be selected by the user in CAPI for each Objective Yield Sample form before proceeding.

Please read the selections from the drop-down menus carefully before selecting the code that identifies the current status of the sample being enumerated.

**\*\*\*Status codes differ across all Objective Yield forms for all crops\*\*\***

### Corn Form A Status Code Definitions:

#### 1- Complete

First Visit: The enumerator was able to get permission to visit the field, lay out the sample units and complete the Form A.

Minimum data requirement for Status Code 1:

- Interview date must be entered
- Questions 1-5 must be positive where applicable (102-105)
- Enumerator and supervisor number must be entered
- Status Code 1 must be selected (180)

#### 7- Refusal

Any Visit: The farmer refused to participate in the survey in the Form A-1 interview or decided they do not want samples laid out in the field.

Future Visits: No future visits will be required.

Minimum data requirement for Status Code 7:

- Interview date must be entered
  - Status Code 7 must be selected (180), no other data is required.
- Enumerator and supervisor number must be entered.  
Put in Form B and E (if applicable) as refusals as well

#### 13- No Corn for Harvest as Grain on Entire Farm

First Visit: No Corn was planted for harvest as grain on the entire farm at the time the Form A-1 interview was conducted.

Future Visits: No future visits will be required.

Minimum data requirement for Status Code 13:

- Interview date must be entered
  - Status Code 13 must be selected (180), no other data is required
- Enumerator and supervisor number must be entered  
Put in Form B and E (if applicable) as No Corn as well

When Corn Form A Status Code is:	Is Form A Expected Next Month?
1- Complete (Form A expected next visit)	<b>NO</b>
7- Refusal	<b>NO</b>
13- No winter corn for harvest as grain on entire farm	<b>NO</b>

CAPI Response Coding and Where to Enter Comments

After Form A data entry is completed select the following response codes in the submission screen. See below for comments entry example.

Item	Response Coding Used for OY Surveys
<b>Response:</b>	Completed
<b>Respondent:</b>	(Who Responded)
<b>Respondent</b>	(Leave Empty)
<b>Respondent</b>	Telephone on iPad
<b>Enumerator:</b>	Auto coded from Assignment Listing
<b>Comments:</b>	General survey comments from the paper form should be entered in the comments icon. Comments that are related to a particular cell or item can be entered in item level comments, accessible via calculator icon.

ENUMERATOR
FORM A 1 WINTER WHEAT YIELD SURVEY

Response:

Respondent:

Responded By (Enter respondent's name, if not the operator):

Reporting Mode:

Enumerator:

PREVIOUS
NEXT

**CAPI Form B Status Codes**

Prior to the implementation of CAPI data collection in the Objective Yield Survey status codes were determined by the survey statistician based on the data reported by the enumerator who completed the form.

The status code is used to identify the sample's status for the current enumeration period based upon recorded observations.

A status code must be selected by the user in CAPI for each Objective Yield Sample form before proceeding.

Please read the selections from the drop-down menus carefully before selecting the code that identifies the current status of the sample being enumerated.

**\*\*\*Status codes differ across all Objective Yield forms for all crops\*\*\***

## Corn Form B Status Code Definitions:

### 1- Complete (Form B expected Next Visit)

The sample field is standing for harvest and sample unit measurements have been recorded. A Form B will be expected next month.

If 3 or more ears in the measurement area are maturity code 6, follow the procedures for code 6 ears outlined in Chapter 5.

First Visit: Complete Form B to meet minimum data requirements for Status Code 1.

Future Visits: The enumerator will return to the sampled field to record measurements for both units and complete Form B accordingly each month until the sample units are mature enough to perform pre-harvest procedures and send the final pre-harvest sample to the national laboratory for processing.

Minimum Data Required for Status Code 1:

- Record Fieldwork Date
- Unit Location Codes must be 1-3 (302, 307)
- Row Space Measurements (303, 304, 305, 306) must be empty when Unit Location Code = 3
- Maturity Code: (301)
- If ears or silked ear shoots are not yet present on the 5 ears, Check  and complete Item 11 only.
- If ears or silked ear shoots **are** present and fewer than 3 ears have a maturity code of 7 and field is **not expected** to be harvested within the next 3 days.
  
- Items in questions 7-14 must be completed where applicable (320-364)
- Status Code 1 must be selected (380) **Form B is expected next month.**

### 2- Farmer Harvested for Grain Before Units Were Laid Out

The sample field was harvested for grain before sample was laid out. No alternate field is available in the tract.

First Visit: Add comment explaining the situation on Form B/in Enumerator Comment area of CAPI instrument. If a Gleanings sample, add fieldwork date and comment explaining the situation on Form E. Complete Form B to meet minimum data requirements for Status Code 2.

Future Visits: No future visit will be required. Minimum Data Required for Status Code 2:

- Record Fieldwork Date
- Status Code 2 must be selected (380), no other data is required Form B is **not** expected next month.

### 3- Farmer Harvested for Grain after Units were Laid Out

Sample units were laid out previously, but were harvested for grain by the farmer before the current month's observations could be completed.

First Visit: Add comment explaining the situation on Form B/in Enumerator Comment area of CAPI instrument. If a Gleanings sample, add fieldwork date and comment explaining the situation on Form E. Complete Form B to meet minimum data requirements for Status Code 3.

Future Visits: No future visit will be required. Minimum Data Required for Status Code 3:

- Record Fieldwork Date
- Status Code 3 must be selected (380), no other data is required Form B is **not** expected next month.

### 4- Enumerator Harvested Sample Units

Corn in sample units was final harvested by the enumerator. Three or more ears are maturity code 7 or farmer will harvest within 3 days. Perform pre-harvest procedures for each sample unit, package, and send the samples to the national laboratory according to specifications outlined in this manual.

Pre-Harvest: Complete Form B to meet minimum data requirements for Status Code 4.

Future Visits: Gleanings samples (*sample numbers that are a multiple of 4, i.e. 4, 8, 12...*) will only require a future visit; within 3 days of farmer harvest.

No future visit will be required for non-gleanings samples.

Minimum Data Required for Status Code 4:

- Record Fieldwork Date
- Unit Location Codes must be 1-3 (302, 307)
- Row Space Measurements (303, 304, 305, 306) must be empty when Unit Location Code = 3
- Maturity Code: (301)
- 3 or more ears must be in code 7 or field is expected to be harvested within 3 days.
- Items in question 11 must be completed where applicable (331-334)
- Items in question 14 must be completed where applicable (361-364)
- Items in question 15 must be completed where applicable (312-313)
- Items in question 16 must be completed where applicable (314-315)
- Status Code 4 must be selected (380) Form B is **not** expected next month.

### 5- Field Partially Destroyed – Both Units Destroyed

The part of the field containing both sample units was destroyed, plowed-up, or abandoned by the farmer (was not harvested for grain). This situation commonly occurs in instances where the sampled field has incurred severe damage from weather (wind, hail, etc.), fire, vandalism, etc. Part of the field remains for harvest as grain.

Return Gleanings Form E samples to the Regional Office noting the field was destroyed and no field was available for gleaning.

**Any Visit:** Add comment explaining the situation on Form B/in Enumerator Comment area of CAPI instrument. If a Gleanings sample, add fieldwork date and comment explaining the situation on Form E. Complete Form B to meet minimum data requirements for Status Code 5.

**Future Visits:** No future visit will be required. Minimum Data Required for Status Code 5:

- Record Fieldwork Date
- Status Code 5 must be selected (380) Form B is **not** expected next month.

### 6- Lost Sample – Field NOT Harvested for Grain

The sample field was NOT harvested for grain. During the initial interview, the farmer indicated the field would be harvested for grain and the sample units were laid out by the enumerator. However, since the initial visit, the entire sample field was destroyed, plowed-up, pastured, cut for silage or abandoned by the farmer.

**Do not use status code 6 if the sample field has been harvested for grain** but the field was plowed, grazed, etc. before the final pre-harvest observations could be made, use status code 3.

**Any Visit:** Confirm the field will not be harvested for grain with producer and complete form B accordingly. Add comment explaining the situation on Form B/in Enumerator Comment area of CAPI instrument. If a Gleanings sample, add fieldwork date and comment explaining the situation on Form E. Complete Form B to meet minimum data requirements for Status Code 6.

**Future Visits:** No future visit will be required. Minimum Data Required for Status Code 6:

- Record Fieldwork Date
- Status Code 6 must be selected (380) Form B is **not** expected next month.

### 7- Refusal

The farmer refused to participate in the survey in the Form A interview or decided they no longer wish to participate after samples were laid out in the field.

**Any Visit:** Add comment explaining the situation on Form B/in Enumerator Comment area of CAPI instrument. If a Gleanings sample, add fieldwork date and comment explaining the situation on Form E. Complete Form B to meet minimum data requirements for Status Code 7.

**Future Visits:** No future visit will be required. Minimum Data Required for Status Code 7:

- Record Fieldwork Date
- Status Code 7 must be selected (380), no other data is required Form B is **not** expected next month.

### 8- Inaccessible (Form B expected Next Visit)

Sample units are standing for harvest, but are inaccessible by the enumerator this month. This occurs in instances where enumeration for the survey month was prohibited by weather, field point of access was closed, locked, recent chemical applications, etc.

Form B cannot be inaccessible the last survey month of the year. If no pre-harvest data can be collected, use status code 2 or 3 as the final Form B for the season.

**Any Visit:** Add comment explaining the situation on Form B/in Enumerator Comment area of CAPI instrument. Complete Form B to meet minimum data requirements for Status Code 8.

**Future Visits:** Return to field as normally scheduled. Minimum Data Required for Status Code 8:

- Record Fieldwork Date
- Status Code 8 must be selected (380), no other data is required Form B is **expected** next month.

### **11- Sample Field Planted to Corn but Not For Harvest as Grain**

Sample field was planted to corn but not for harvest as grain. During the initial interview, the farmer indicated that the selected sample field will not be harvested as grain. No sample units were laid out. Sample fields expected for harvest as silage should be a Status Code 11.

First Visit: Add comment explaining the situation on Form B/in Enumerator Comment area of CAPI instrument. If a Gleanings sample, add fieldwork date and comment explaining the situation on Form E. Complete Form B to meet minimum data requirements for Status Code 11.

Future Visits: No future visit will be required. Minimum Data Required for Status Code 11:

- Record Fieldwork Date
- Status Code 11 must be selected (380), no other data is required Form B is **not** expected next month.

### **12- Corn for Grain in Tract but Not Planted for ANY Purpose in the Sample Field**

During the initial interview, the farmer indicated that the selected sample field was planted to corn for grain, however the field was discovered to be planted to another crop. No sample field is available to be surveyed.

First Visit: Add comment explaining the situation on Form B/in Enumerator Comment area of CAPI instrument. If a Gleanings sample, add fieldwork date and comment explaining the situation on Form E. Complete Form B to meet minimum data requirements for Status Code 12.

Future Visit: No future visit will be required. Minimum Data Required for Status Code 12:

- Record Fieldwork Date
- Status Code 12 must be selected (380), no other data is required Form B is **not** expected next month.



**13- No Corn Planted For ANY Purpose in Tract**

During the initial interview, the farmer indicated they did not plant any corn in the entire segment. No sample fields available to be surveyed.

First Visit: Add comment explaining the situation on Form B/in Enumerator Comment area of CAPI instrument. If a Gleanings sample, add fieldwork date and comment explaining the situation on Form E. Complete Form B to meet minimum data requirements for Status Code 13.

Future Visit: No future visit will be required. Minimum Data Required for Status Code 13:

- Record Fieldwork Date
- Status Code 13 must be selected (380), no other data is required Form B is **not** expected next month.

**Status Code Summary:**

When Corn Form B Status Code is:	Is Form B Expected Next Month?
1 Complete	YES
-	
2 Farmer Harvested for Grain <b>before</b> Units Were Laid Out	NO
-	
3 Farmer Harvested for Grain <b>after</b> Units were Laid Out	NO
-	
4 Enumerator harvested sample units	NO
-	
5 Field partially destroyed – Both units destroyed	NO
-	
6 Lost Sample – Field <b>NOT</b> harvested for grain	NO
-	
7 Refusal	NO
-	
8 Inaccessible	YES
-	
1 Sample field planted to corn but not for harvest as grain	NO
1	
-	
1 Corn for grain in tract but not planted for ANY purpose in the sample	NO
2 field	
-	
1 No corn planted for ANY purpose in tract	NO
3	
-	

### CAPI Response Coding

After Form B data entry is complete and you have clicked the Finish Button at the bottom of the form to submit the record, select the following response codes in the submission screen for each record.

Item	Response Coding Used for OY Surveys
<b>Response:</b>	Completed
<b>Respondent:</b>	Other
<b>Respondent Name:</b>	(Leave Empty)
<b>Respondent Mode:</b>	Face-to-Face on iPad
<b>Enumerator:</b>	Locked out and auto coded from Assignment Listing
<b>Comments:</b>	Do not enter OY comments on the submission page. All OY survey comments should be made in the Enumerator Comments area at the bottom of the Form B.

📶
FORM B CORN YIELD COUNTS

ASSIGNMENT LISTING ::  
  
DOE FARMS INC

ADDRESS Address verified. Click to make changes.

Response: Completed ▼

Respondent: Other ▼

Respondent Name: (Leave Blank)

Respondent Mode: Face-To-Face on iPad ▼

Enumerator: 05005

**Comments:**

Do not enter OY survey comments on the submission page.

All OY survey comments should be made in the Enumerator Comments area at the bottom of the Form B.

PREVIOUS
SAVE
SAVE FOR REVIEW

FINAL SUBMISSION